

The background is a dark blue to black gradient, featuring several glowing, curved lines in shades of blue and purple. These lines sweep across the frame from the bottom left towards the top right. Interspersed among these lines are numerous small, bright blue and white dots, some of which appear to be part of the glowing lines, creating a sense of motion and energy.

ANLET

3 LOBES BLOWER & VACUUM PUMP

Three-Lobes Blower 3葉アンレットルーツブロウ

Initially, nearly all blowers were of the two-lobed type, and although the design of the three-lobed type was understood to offer the advantages lower noise and vibration as well as greater efficiency, construction was difficult. Anlet alone has been able to produce high-performance yet low-cost blowers using a patented three-lobe rotor machining tool.

ルーツブロウは初期の頃から2葉式がその殆どであり、3葉式は構造上、低騒音・低振動・高効率と分かりながら製作上むずかしく、アンレットだけが特許取得の3葉ロータ専用加工機によって高精度で、しかも価格の安いロータを生産可能とし、日本で初めて量産化に成功しました。

ANLET Roots Blower's Strong Point アンレットルーツブロウの特長

1. The three-lobe Roots-type rotor and double helical casing radically reduce noise and vibrations. The addition of endless casing has met the goal of energy savings.
2. ANLET blowers blow clean air free from admixed oil, so there is no dispersion of oil mist to foul the environment.
3. All-in-one rotor/shaft unit is wear-free, allowing for long-term continuous operation with no deterioration in blower performance.
4. Don't be fooled by their compact size. These are highly efficient blowers that can be operated at high speed.
5. Simple structure and special bearings that allow for grease replenishment give these blowers outstanding durability.
6. Each unit is equipped with a gear oil overshooter to prevent oil leakage problems.
7. Models are numerous and varied, meaning you can choose just the right type for your purposes.

1. 3葉ルーツ式ロータおよびダブルヘリカルケーシングのため騒音・振動が非常に小さく、又、エンドレスケーシング方式で省エネルギー化を達成しました。
2. 無混油のため清浄な空気が得られ、オイルミストの飛散による汚染がありません。
3. ロータとシャフトが一体型で、しかも摩耗がないため、いつまでもブロウ能力に変化がなく、長期連続運転が可能です。
4. 高速化が可能で、高効率です。又、非常にコンパクトです。
5. 構造が簡単で、グリス補給可能な特殊ベアリングを採用しており、耐久力が抜群です。
6. ギヤオイル振り切り機構付きで、オイルもれのトラブルがありません。
7. 機種が豊富で用途に応じて選定できます。

“Endless” Construction エンドレス方式

By enlarging the communicating angle between the casing's intake opening and exhaust opening, it has been possible to continuously maintain an intermediate chamber enveloped by rotor and casing in between the outlet and inlet sides of the unit. The pressure in this intermediate chamber lies between the intake and exhaust pressures, and the decrease in differential pressure between them saves energy because it makes for less leakage between rotor and casing at the same time that it improves the unit's volumetric efficiency and mechanical efficiency. This special design makes it difficult for the high-temperature air on the outlet side to return to the inlet side. The unit as a whole heats up far less than conventional blowers, allowing for operation at a higher load. As an added benefit, the smaller rise in temperature keeps the noise of bearings and timing gear to a minimum, while the low transmission of noise to the intake side makes the blower into an all-around quiet-running unit.

ケーシングの吸込口と吐出口の連通角度を大きくすることで、吸込側と吐出側の間にロータとケーシングで包まれた中間室が常にできます。この中間室の圧力は吐出側圧力と吸込側圧力との間の圧力となり、差圧が小さくなるためロータ・ケーシング間のリーク量が減り、容積効率及び機械効率がよくなり、省エネとなります。また、吐出側の高温空気が吸込側までもどりにくいことにより、全体の温度上昇が少なく、より高負荷まで運転可能となります。さらに、温度上昇が少ないことにより、ベアリングやタイミングギヤの音も低くなり、吸込側への音の伝達も少ないため全体の騒音が小さくなります。

Endless Casing エンドレスケーシング

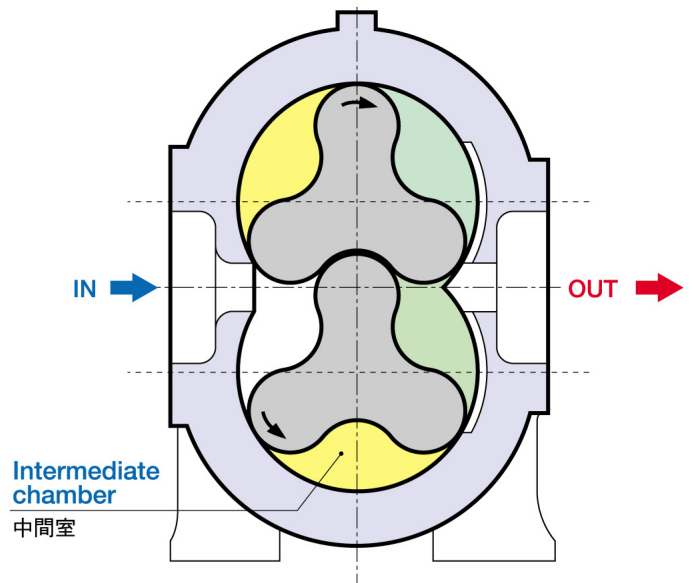

Conventional type 従来型

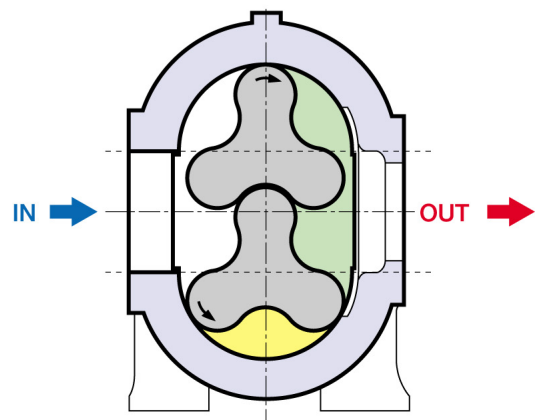

Operating Principle 作動原理

The blower is a displacement blower, and sends a fixed amount of air in proportion to its rotation speed. With the three-lobed rotors, the two rotors make six intake and exhaust cycles per revolution, and because the air has less pulses than with the two-lobed type, fluctuations in load are small, mechanical strength is high, and less noise and vibration are generated.

Figure 1 shows the operation principle.

While the two three-lobed rotors mounted on two parallel shafts maintain only a very small clearance between themselves and the inner surface of the oval casing operating chamber and between each other, they are rotated in opposite directions at an equal speed, moving a fixed volume of the air enclosed by the casing and rotors from the intake side to the output side. Because each rotor phase is synchronized correctly by a timing gear, there is no contact. This permits high speed and eliminates the need for internal lubrication. Moreover, the simple design, easy handling, and stable performance make possible a wide range of applications.

ルーツブロワは容積式のブロワであり、回転速度に比例した一定量の気体が送り出されます。3葉ロータの場合は1回転当たり2つのロータで6回の吸・排気が行われ、2葉式に比べて気体の脈動が少いため荷重変動が小さくなり、機械的強度が高く、騒音・振動の発生が少なくなります。

2本の平行な軸上に取り付けられた2個の3葉断面のロータが長円形のケーシング(作動室)内面、および相互のロータ間にわずかな隙間を保持しつつ、互いに反対方向に等速度で回転することにより、ケーシングとロータで囲まれた一定量の容積の気体を吸込側から吐出側へ送り出します。

各々のロータはタイミングギヤによって位相が正しく保たれているため、接触することはありません。したがって高速化が可能で、内部潤滑が不要です。しかも、構造が簡単で、取扱いも容易であり、性能も安定しているため種々の用途に幅広く利用されています。

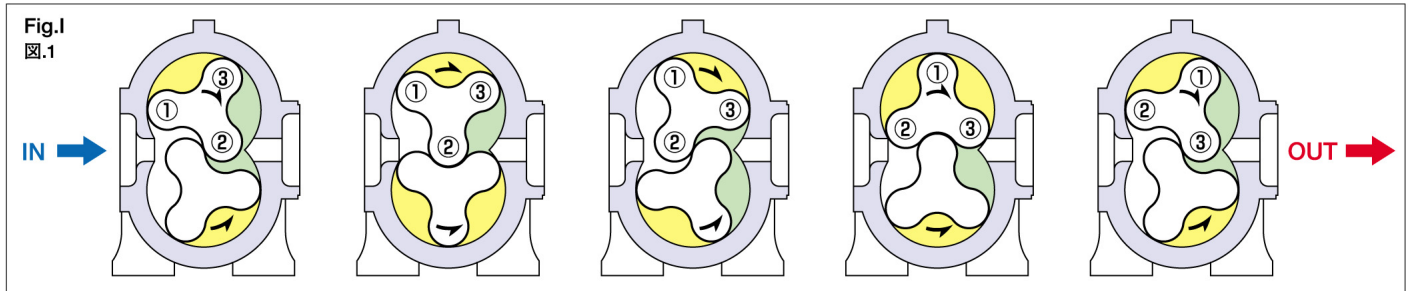

ANLET Vacuum Pump's Strong Point アンレット真空ポンプの特長

1. Endless casing, high efficiency, low noise.
2. Split casing for easier disassembly and internal inspection.
3. Integrated rotor and shaft configures three lobe rotor for low noise and low vibration.
4. No internal lubricants used eliminates oil backflow into vacuum side resulting to continues vacuum.
5. No oil mist scatter at discharge side for clean working environment and protect worker's health.
6. Can run under atmospheric pressure, stable performance over wide range of pressure <Shut off operation capable>
7. Wear free allows for long term continuous operation, simplifies maintenance management.
8. Compressed gas drain recovery possible.
9. Simple construction with exceptional durability.

1. エンドレスケーシングで高効率・低騒音です。
2. 分割ケーシングのため分解及び内部点検が容易です。
3. ロータとシャフトが一体形の三葉ルーツ式ロータのため低騒音・低振動です。
4. 内部潤滑剤を使用しないため高真空側への油の逆流がなく、きれいな真空が得られます。
5. 吐出側にオイルミストの飛散がなく、作業環境及び作業者の健康を守ります。
6. 大気圧からの運転が可能で、広い圧力範囲にわたり性能が安定しています。〈締切運転可能です。〉
7. 摩耗がないため長期連続運転ができ、維持管理も簡単です。
8. 凝縮性気体のドレン回収も可能です。
9. 構造が簡単で、耐久力が抜群です。

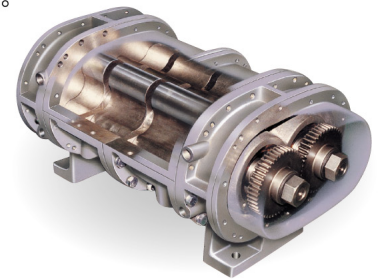

Problems with other products 他の製品の問題点

Water seal vacuum pump 水封式真空ポンプ

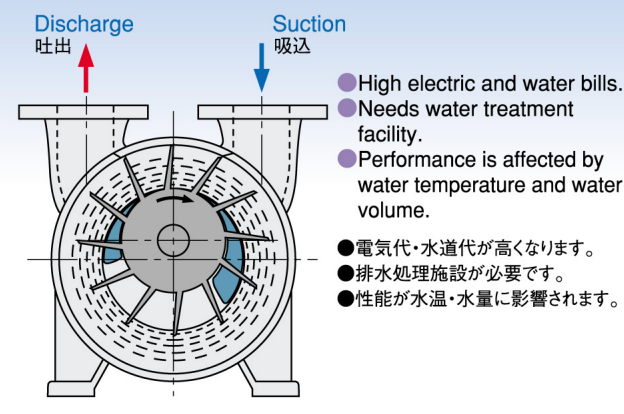

Hydraulic rotary vacuum pump 油回転式真空ポンプ

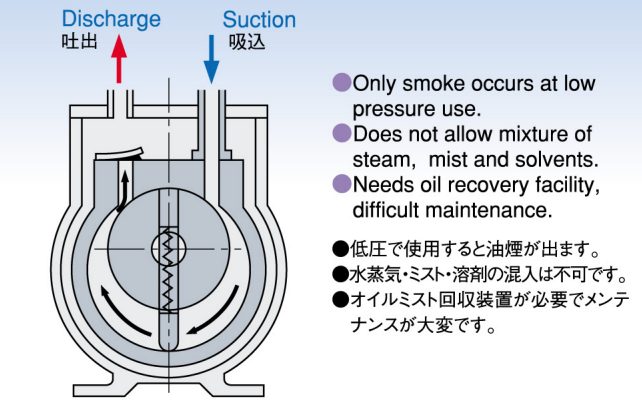

Points to Keep in Mind When Making a Selection

機種選定に際して

1	Model 型式	
2	Application 用途	
3	Pressure 圧力	
4	Capacity 空気量	
5	Motor モーター <ul style="list-style-type: none"> ・ Type 型式 ・ Output 出力 ・ Voltage 電圧 ・ Hz 周波数 ・ Pole 極数 	
6	For Air or Gas ? ガスの種類 <ul style="list-style-type: none"> ・ Name ガス名、状態、温度 ・ Corrosive or explosion 腐食性、爆発性の有無 ・ Gravity of mix gas 混合ガスの場合は組成比・分子量 	
7	Serial number 製造番号	
8	Company name 会社名	
9	The space of installation 設置の場所 <ul style="list-style-type: none"> ・ Indoor or outdoor 屋内・屋外の区分 ・ The surrounding temperature 周囲温度 ・ Safety or dangerous position 危険場所の有無 ・ Frequency 周波数 ・ Voltage 電圧 	
10	Other その他 <ul style="list-style-type: none"> ・ Temperature of cooling water 冷却水温度 ・ Operation time 運転時間 ・ Accessories 付属品 ・ Spare parts 予備品 ・ Color 塗装色 	

● Conversion Rate Table 換算率表

Conversion table for pressure units that present a problem due to the switch to SI units
 SI単位への切替えで問題になる圧力単位の換算率表

	Pa	kPa	MPa	bar	kgf/cm ²	atm	mmH ₂ O (mmAq)	mmHg Torr
pressure	1	1×10 ⁻³	1×10 ⁻⁶	1×10 ⁻⁵	1.019 72×10 ⁻⁵	9.869 23×10 ⁻⁶	1.019 72×10 ⁻¹	7.500 62×10 ⁻³
	1×10 ³	1	1×10 ⁻³	1×10 ⁻²	1.019 72×10 ⁻²	9.869 23×10 ⁻³	1.019 72×10 ²	7.500 62
	1×10 ⁶	1×10 ³	1	1×10	1.019 72×10	9.869 23	1.019 72×10 ⁵	7.500 62×10 ³
	1×10 ⁵	1×10 ²	1×10 ⁻¹	1	1.019 72	9.869 23×10 ⁻¹	1.019 72×10 ⁴	7.500 62×10 ²
圧力	9.806 65×10 ⁴	9.806 65×10	9.806 65×10 ⁻²	9.806 65×10 ⁻¹	1	9.678 41×10 ⁻¹	1×10 ⁴	7.355 59×10 ²
	1.013 25×10 ⁵	1.013 25×10 ²	1.013 25×10 ⁻¹	1.013 25	1.033 23	1	1.033 23×10 ⁴	7.600 00×10 ²
	9.806 65	9.806 65×10 ⁻³	9.806 65×10 ⁻⁶	9.806 65×10 ⁻⁵	1×10 ⁻⁴	9.678 41×10 ⁻⁵	1	7.355 59×10 ⁻²
	1.333 22×10 ²	1.333 22×10 ⁻¹	1.333 22×10 ⁻⁴	1.333 22×10 ⁻³	1.359 51×10 ⁻³	1.315 79×10 ⁻³	1.359 51×10	1

Example of usage at discharging model

吐出仕様用途例

Water Treatment

水処理

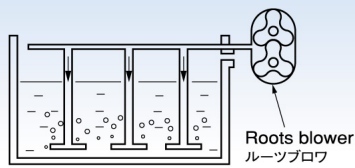

Blowers are used to purify water and stir up sediment at water treatment plants.
水処理プラントの浄化用や沈殿物の攪拌用に使用されています。

Incinerators

焼却炉

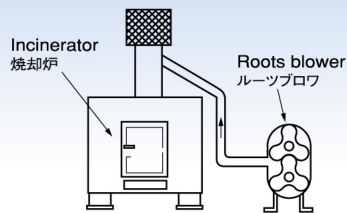

Blowers enhance combustion efficiency and promote the removal of exhaust gases.
燃焼効果を助けたり、排気ガスの除去を促したりすることができます。

Cleaning of Pipes

配管の清掃

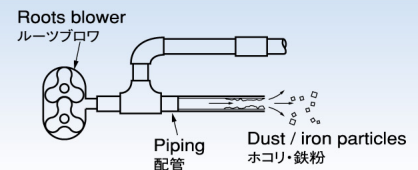

Blowers can be used to remove dust and iron particles when piping is replaced or periodically checked. They can also be used to supply various kinds of coating material to the interior of pipes.
配管の取替えや定期点検の際に生じるホコリや鉄粉等を取り除きます。また、配管内の各種コーティング材供給用にも利用されています。

Air Blower

エアブロー

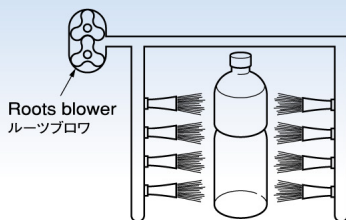

Here blower is used to blow off drops of water clinging to surfaces of cans, bottles, machine parts, etc. Air blowers can also be used as sources of cooling or drying air.
缶・ビン類および機械部品等の水きりに使用されています。他に、冷却・乾燥源としても利用されています。

Plating Bath

メッキ槽

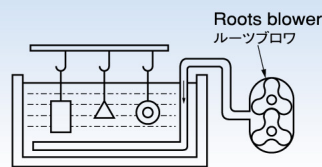

Plating quality can be enhanced by using a blower to circulate electrolytes in the plating bath to give the plating a more uniform thickness. Here blowers serve as the source of air supply.
メッキの高品質化(メッキ厚平均化)のために槽内に空気を送って電解物を循環させますが、その空気源として利用されています。

Paper Feed for Printers

印刷機の紙送り

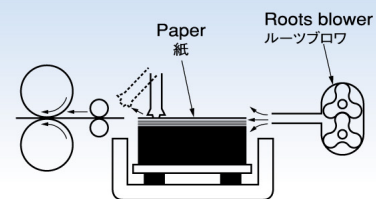

Air discharged from blowers facilitates the separation of sheets of paper as well as their distribution in neat piles after printing.
吐出空気紙を分離し、紙をそろえたり配ったりする作業を容易にします。

Frozen Food

食品解凍

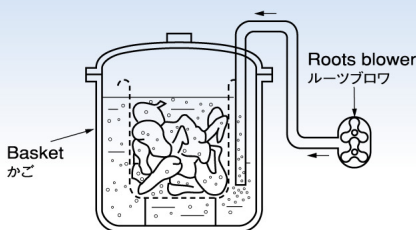

Blowers are useful in the stir-freezing of frozen foods in water.
冷凍食品等を水中で攪拌解凍するために利用されています。

Oxygen Supply for Aquafarms

養殖池の酸素補給

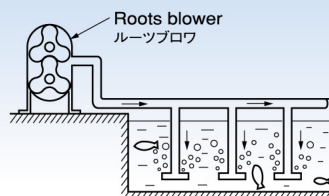

Aquafarms producing all sorts of fish and shellfish use blowers to oxygenate and circulate the water in tanks. Blowers are also used for aquariums and live fish tanks.
各種魚介類の養殖池で、水中への酸素補給及び攪拌用として使用されています。また、水族館や活魚槽でも利用されています。

Sand blasting

サンドブラスト

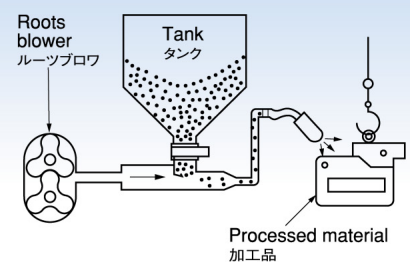

Provides a concentrated blast of air for use in sandblasting.
サンドブラストの吹き付け空気源として使用されています。

Airlift Pump

エアリフトポンプ

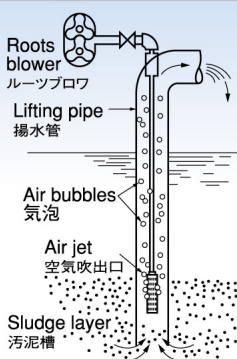

Bubbles formed by air jet lift water through the pipe by reducing the specific gravity of sewage.
エアによる気泡で汚水等の比重が小さくなり揚水ができます。

Press

プレス機

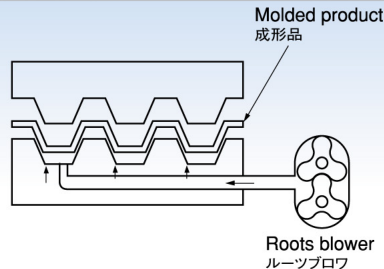

Blower is used for lift when removing molded products from the press.
プレスされた成形品を型からはずすのに利用されています。

Particle Transportation

粉粒体の輸送

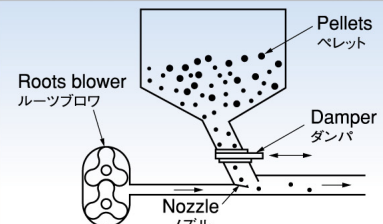

Blower is used for the pneumatic conveyance of pelletized raw materials such as vinyl chloride and polyethylene (The vacuum method will work here as well).
塩化ビニール、ポリエチレン等のペレット状原料の空気輸送に使用されます。(吸引式も可能)

BE-H Type

● Performance Chart 性能表 (1m³/min≒35.315CFM)

Model 型式	Bore 口径	min ⁻¹ 回転速度	10kPa (1020mmAq)		20kPa (2040mmAq)		30kPa (3060mmAq)		40kPa (4080mmAq)		50kPa (5100mmAq)		60kPa (6120mmAq)		70kPa (7140mmAq)		80kPa (8160mmAq)		
			m ³ /min	kW	m ³ /min	kW	m ³ /min	kW	m ³ /min	kW	m ³ /min	kW	m ³ /min	kW	m ³ /min	kW	m ³ /min	kW	
BE 50E	2B	2200	1.40	0.7	1.31	1.0	1.22	1.2	1.13	1.5	1.04	1.9							
		2500	1.66	0.8	1.57	1.1	1.48	1.4	1.39	1.8	1.30	2.2							
		2750	1.87	0.9	1.78	1.2	1.69	1.6	1.60	2.0	1.51	2.5							
		3050	2.12	1.0	2.03	1.4	1.94	1.8	1.85	2.3	1.76	2.7							
		3300	2.34	1.0	2.25	1.5	2.16	1.9	2.07	2.4	1.98	2.9							
		3600	2.59	1.1	2.50	1.6	2.41	2.1	2.32	2.6	2.23	3.2							
BE 65H	2½B	2100	2.35	1.0	2.31	1.4	2.27	1.9	2.24	2.4	2.20	3.0	2.16	3.5	2.12	4.1	2.08	4.6	
		2350	2.70	1.1	2.66	1.6	2.62	2.2	2.59	2.7	2.55	3.3	2.51	3.9	2.47	4.5	2.43	5.1	
		2450	2.84	1.1	2.80	1.7	2.76	2.3	2.73	2.9	2.69	3.5	2.65	4.1	2.61	4.7	2.57	5.4	
		2600	3.05	1.2	3.01	1.8	2.97	2.4	2.94	3.0	2.90	3.7	2.86	4.4	2.82	5.1	2.78	5.8	
		2750	3.26	1.3	3.22	2.0	3.18	2.6	3.15	3.2	3.11	3.9	3.07	4.6	3.03	5.3	2.99	6.0	
		2900	3.47	1.4	3.43	2.1	3.39	2.7	3.36	3.4	3.32	4.2	3.28	4.9	3.24	5.7	3.20	6.4	
		3250	3.96	1.5	3.92	2.3	3.88	3.0	3.85	3.8	3.81	4.7	3.77	5.5	3.73	6.3			
BE 80H	3B	2100	3.81	1.4	3.73	2.2	3.65	2.9	3.57	3.7	3.49	4.5	3.41	5.4	3.33	6.2	3.25	7.1	
		2350	4.25	1.6	4.17	2.4	4.09	3.2	4.01	4.1	3.93	5.0	3.85	5.9	3.77	6.7	3.69	7.6	
		2450	4.47	1.6	4.39	2.5	4.31	3.4	4.23	4.3	4.15	5.2	4.07	6.2	3.99	7.1	3.91	8.0	
		2600	4.80	1.7	4.72	2.6	4.64	3.6	4.56	4.5	4.48	5.6	4.40	6.6	4.32	7.6	4.24	8.6	
		2750	5.13	1.9	5.05	2.8	4.97	3.8	4.89	4.9	4.81	6.0	4.73	7.1	4.65	8.1	4.57	9.2	
		2900	5.46	2.0	5.38	3.0	5.30	4.1	5.22	5.2	5.14	6.4	5.06	7.5	4.98	8.7	4.90	9.8	
		3250	6.23	2.1	6.15	3.4	6.07	4.6	5.99	5.9	5.91	7.2	5.83	8.6	5.75	9.9			
BE100H	4B	2050	5.79	2.1	5.64	3.2	5.50	4.3	5.35	5.4	5.21	6.6	5.06	7.8	4.91	9.0	4.76	10.2	
		2150	6.12	2.2	5.97	3.3	5.83	4.5	5.68	5.7	5.54	6.9	5.39	8.1	5.24	9.4	5.09	10.7	
		2300	6.60	2.4	6.45	3.6	6.31	4.8	6.16	6.1	6.02	7.3	5.87	8.7	5.72	10.0	5.57	11.4	
		2400	6.92	2.5	6.77	3.7	6.63	5.0	6.48	6.3	6.34	7.6	6.19	9.0	6.04	10.4	5.89	11.8	
		2700	7.88	3.0	7.73	4.4	7.59	5.8	7.44	7.3	7.30	8.8	7.15	10.3	7.00	11.9	6.85	13.4	
		2900	8.52	3.2	8.37	4.8	8.23	6.4	8.08	8.0	7.94	9.6	7.79	11.3	7.64	13.0	7.49	14.7	
		3050	9.00	3.4	8.85	5.1	8.71	6.7	8.56	8.5	8.42	10.2	8.27	12.1	8.12	13.9			
BE125H	5B	1750	8.8	2.8	8.7	4.6	8.6	6.5	8.5	8.3	8.4	10.2	8.3	12.0	8.2	13.8	8.1	15.6	
		1950	10.0	3.0	9.9	5.1	9.8	7.2	9.7	9.3	9.6	11.4	9.5	13.4	9.4	15.5	9.3	17.5	
		2150	11.2	3.4	11.1	5.7	11.0	8.0	10.9	10.3	10.8	12.6	10.7	14.9	10.6	17.2	10.5	19.4	
		2400	12.7	3.9	12.6	6.5	12.5	9.0	12.4	11.6	12.3	14.2	12.2	16.8	12.1	19.4	12.0	22.0	
		2700	14.5	4.6	14.4	7.4	14.3	10.4	14.2	13.2	14.1	16.2	14.0	19.1	13.9	22.1	13.8	25.0	
		2900	15.7	5.0	15.6	8.0	15.5	11.1	15.4	14.3	15.3	17.5	15.2	20.6	15.1	23.8	15.0	27.0	
		3050	16.6	5.3	16.5	8.4	16.4	11.7	16.3	15.1	16.2	18.4	16.1	21.8	16.0	25.1	15.9	28.5	
BE150H	6B	1550	17.5	4.9	17.2	8.4	16.9	11.9	16.6	15.3	16.3	18.7	16.0	22.1	15.7	25.5	15.4	28.9	
		1700	19.4	5.6	19.1	9.4	18.8	13.2	18.5	16.9	18.2	20.7	17.9	24.4	17.6	28.1	17.3	31.8	
		1800	20.7	6.0	20.4	10.0	20.1	14.0	19.8	18.0	19.5	22.0	19.2	25.9	18.9	29.8			
		1950	22.6	6.7	22.3	11.0	22.0	15.3	21.7	19.6	21.4	23.9	21.1	28.2	20.8	32.4			
		2100	24.5	7.3	24.2	11.9	23.9	16.6	23.6	21.2	23.3	25.9	23.0	30.5	22.7	35.1			
		2250	26.5	8.0	26.2	13.0	25.9	18.0	25.6	22.9	25.3	27.8	25.0	32.8	24.7	37.8			
		2550	30.3	9.2	30.0	14.8	29.7	20.5	29.4	26.2	29.1	31.8	28.8	37.5	28.5	43.2			
BE200H	8B	1450	33.0	9.1	32.8	15.2	31.6	21.5	30.9	28.0	30.2	34.7	29.5	41.7	28.8	48.7	28.1	55.7	
		1550	35.6	9.9	35.4	16.3	34.2	23.0	33.5	30.0	32.8	37.2	32.1	44.7	31.4	52.2	30.7	59.8	
		1700	39.4	11.2	39.2	18.1	38.0	25.4	37.3	33.0	36.6	40.9	35.9	49.3	35.2	57.6	34.5	65.9	
		1800	42.0	12.1	41.8	19.4	40.6	27.0	39.9	35.0	39.2	43.5	38.5	52.4	37.8	61.3			
		1950	45.8	13.6	45.6	21.4	44.4	29.5	43.7	38.3	43.0	47.4	42.3	57.1	41.6	66.9			
		2050	48.3	14.7	48.1	22.8	46.9	31.2	46.2	40.6	45.5	50.2	44.8	60.4	44.1	70.6			
		2150	50.9	15.9	50.7	24.3	49.5	33.1	48.8	42.9	48.1	53.1	47.4	63.8	46.7	74.5			
BE250H	10B	1250	52.4	17.9	51.7	27.2	51.0	36.6	50.3	46.6	49.6	56.1	48.9	66.1	48.2	76.1	47.5	86.1	
		1350	57.0	19.5	56.3	29.6	55.6	39.8	54.9	50.6	54.2	60.9	53.5	71.7	52.8	82.5			
		1450	61.6	21.1	60.9	32.0	60.2	43.1	59.5	54.7	58.8	65.7	58.1	77.3	57.4	88.9			
		1600	68.6	23.5	67.9	35.5	67.2	48.0	66.5	60.9	65.8	73.0	65.1	85.9	64.4	98.8			
		1700	73.2	25.0	72.5	37.8	71.8	51.3	71.1	65.0	70.4	77.8	69.7	91.5	69.0	105			
		1800	77.8	26.6	77.1	40.2	76.4	54.6	75.7	69.0	75.0	82.6	74.3	97.2	73.6	112			
		1950	84.8	29.0	84.1	43.8	83.4	59.5	82.7	75.1	82.0	89.9	81.3	106	80.6	122			
BE300H	12B	1300	73.5	20.3	72.5	35.5	71.5	50.7	70.5	65.8	69.5	81.0	68.5	96.1					
		1350	76.8	21.4	75.8	37.2	74.8	52.9	73.8	68.6	72.8	84.4	71.8	100					
		1450	83.3	23.5	82.3	40.5	81.3	57.4	80.3	74.2	79.3	91.2	78.3	108					
		1550	89.9	26.1	88.9	44.1	87.9	62.2	86.9	80.2	85.9	98.2	84.9	116					
		1650	96.4	28.6	95.4	47.9	94.4	67.1	93.4	86.4	92.4	106	91.4	125					
		1750	103	31.4	102	51.8	101	72.2	100	92.6	99.0	113	98.0	133					

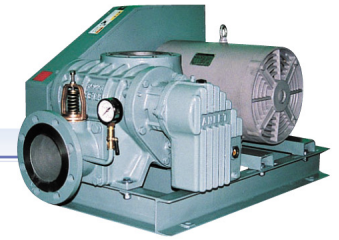

Model 型式	Bore 口径	min ⁻¹ 回転速度	10kPa (1020mmAq)		20kPa (2040mmAq)		30kPa (3060mmAq)		40kPa (4080mmAq)		50kPa (5100mmAq)		60kPa (6120mmAq)		70kPa (7140mmAq)		80kPa (8160mmAq)	
			m ³ /min	kW	m ³ /min	kW	m ³ /min	kW	m ³ /min	kW	m ³ /min	kW	m ³ /min	kW	m ³ /min	kW	m ³ /min	kW
BE350H	14B	1200	109	27.5	107	48.2	106	68.8	104	89.5	103	110	101	131				
		1300	119	31.0	117	53.6	116	76.2	114	98.8	113	121	111	144				
		1350	124	32.8	122	56.3	121	80.0	119	103	118	127	116	151				
		1450	134	36.3	132	61.8	131	87.4	129	113	128	138	126	164				
		1550	144	39.8	142	67.2	141	94.9	139	122	138	150	136	177				
BE400H	16B	900	161	42	159	73	157	104	155	135	153	166	151	196				
		1050	191	51	189	87	187	123	185	159	183	195	181	232				
		1150	211	57	209	97	207	136	205	176	203	215	201	256				
		1250	230	64	228	107	226	150	224	193	222	236						
		1300	240	68	238	112	236	157	234	201	232	246						
		1350	250	72	248	118	246	165	244	211								

※ Models 型式 50 Hz type: 5BE○○H
60 Hz type: 6BE○○H

section indicates water cooled housing and gear cover
(coolant water volume: 15 to 25 L/min)
ハウジング、ギヤカバー水冷却式(冷却水量15~25L/min)

* If discharge pressure is 61kPa or above, the product is designed to correspond to high-pressure specification. Products of standard specification (less than 60kPa) cannot be used as those of high-pressure specification. Please contact us for further details.

※吐出圧力61kPa以上の場合、高圧仕様対応品となります。標準仕様品(60kPa以下)は高圧仕様では使用できません。詳細は、お問い合わせください。

Outline Drawing 外形寸法図

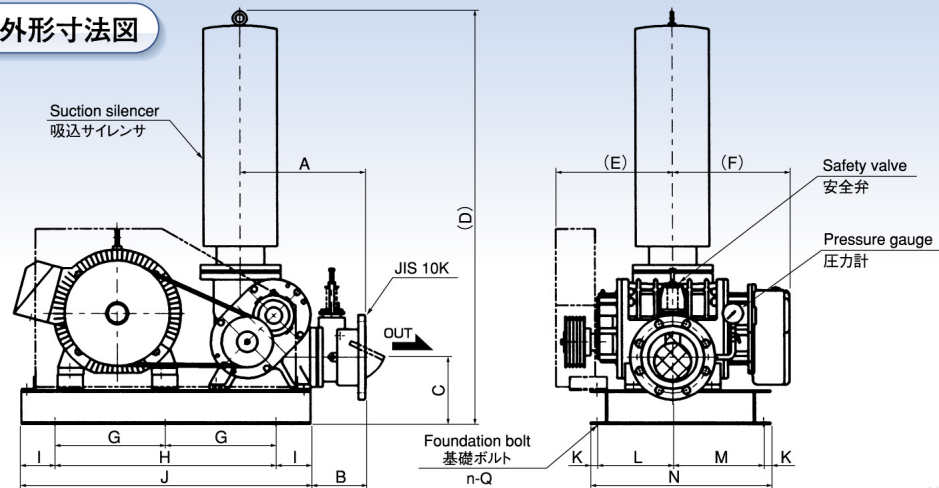

unit 単位: mm

Model 型式	Bore 口径	A	B	C	D	E	F	G	H	I	J	K	L	M	N	n	Q	Weight (kg) 質量
BE 50E	2B	217	100	132	631	235	230	—	450	50	550	18	156	128	320	4	M12	60
BE 65H	2½B	272	132	142	826	225	220	—	550	50	650	18	128	171	335	4	M12	85
BE 80H	3B	277	122	152	908	270	257	—	600	50	700	18	164	250	450	4	M12	115
BE100H	4B	342	153	187	1061	250	275	—	600	100	800	20	133	312	485	4	M12	155
BE125H	5B	367	163	197	1215	345	345	—	650	100	850	20	223	267	530	4	M12	195
BE150H	6B	412	178	212	1296	475	455	—	850	100	1050	20	320	220	580	4	M12	320
BE200H	8B	532	209	262	2010	495	495	475	950	150	1250	30	300	320	680	6	M12	590
BE250H	10B	667	315	297	2090	600	595	575	1150	150	1450	30	389	331	780	6	M12	880
BE300H	12B	842	421	322	2530	640	630	625	1250	150	1550	30	421	339	820	6	M16	1210
BE350H	14B	817	333	414	3120	820	764	725	1450	150	1750	35	785	425	1280	6	M16	1900
BE400H	16B	1072	510	449	3325	1000	953	925	1850	150	2150	35	965	465	1500	6	M18	2900

- The type of BE-E is only BE-50E model.
- The type of BE-H are from BE-65H to BE-400H models.
- Weight shown covers the blower with standard accessories without motor
- Standard accessories: Suction silencer・Safety valve・V-pulley・V-belt・Pressure gauge・Base・Belt cover・Check valve (BE50E~150H)
- Note : Please be aware that the size of the base may differ for special motors (special-configuration motors, heteroelectric motors, motors for exclusive use in inverters, etc.) as well as motors with slide bases.
- Anti-vibration mounts, rubber vibration insulators, and intake silencers with attached air filters are available as options.
- When an inverter is used, control begins with 60 Hz, and so please choose 6BE-H.
- In the case of high-pressure specs, accessories are different from standard ones.
- BE-Eは、BE50E型のみです。
- BE-Hは、BE65HからBE400H型まであります。
- 質量はモータを除いた標準付属品付の値です。※BE350・400の吸込サイレンサ形状は図とは異なります。
- 標準付属品: 吸込サイレンサ (BE50E~150Hはフィルタ付)・圧力計・ベース・ベルトカバー・安全弁・Vプーリー・Vベルト・基礎ボルト・内蔵逆止弁 (BE50E~150H、60kPa以下)
- (注) 特殊モータ (特殊形状モータ、異電圧モータ、インバータ専用モータ etc.) やスライドベース付モータの場合は、ベースの大きさが異なることもありますので、ご了承ください。
- 防振架台・防振ゴム及びエアフィルタ付き吸込サイレンサも用意しております。(オプション)
- インバータ使用時は60Hzからの制御となりますので6BE-Hを選定してください。
- 高圧仕様の場合、付属品が標準と異なります。

BH Type

● Performance Chart 性能表 (1m³/min≒35.315CFM)

Model 型式	Bore 口径	min ⁻¹ 回転速度	10kPa (1020mmAq)		20kPa (2040mmAq)		30kPa (3060mmAq)		40kPa (4080mmAq)		50kPa (5100mmAq)		60kPa (6120mmAq)	
			m ³ /min	kW	m ³ /min	kW	m ³ /min	kW	m ³ /min	kW	m ³ /min	kW	m ³ /min	kW
BH 50	2B	1150	1.50	0.7	1.33	1.0	1.18	1.4	1.04	1.7	0.91	2.0	0.79	2.4
		1250	1.68	0.8	1.51	1.2	1.36	1.5	1.22	1.8	1.09	2.2	0.97	2.6
		1350	1.86	0.9	1.69	1.3	1.54	1.7	1.40	2.0	1.27	2.4	1.15	2.8
		1400	1.95	0.9	1.78	1.3	1.63	1.7	1.49	2.1	1.36	2.5	1.24	2.9
		1550	2.22	1.0	2.05	1.5	1.90	1.9	1.76	2.3	1.63	2.7	1.51	3.2
1700	2.49	1.1	2.32	1.6	2.17	2.1	2.03	2.5	1.90	3.0	1.78	3.5		
BH 65	2½B	1150	1.95	0.8	1.67	1.2	1.45	1.7	1.27	2.1	1.14	2.6		
		1250	2.20	0.9	1.92	1.3	1.70	1.9	1.52	2.4	1.39	2.9	1.29	3.5
		1400	2.58	1.0	2.30	1.5	2.08	2.1	1.90	2.7	1.77	3.3	1.67	3.9
		1550	2.95	1.2	2.67	1.7	2.45	2.3	2.27	3.0	2.14	3.7	2.04	4.4
		1700	3.33	1.3	3.05	1.9	2.83	2.6	2.65	3.3	2.52	4.0	2.42	4.8
BH 80	3B	1150	3.19	1.2	3.03	1.9	2.86	2.6	2.73	3.3	2.63	4.0	2.52	4.7
		1250	3.55	1.3	3.39	2.0	3.22	2.8	3.09	3.6	2.99	4.4	2.88	5.2
		1400	4.09	1.5	3.93	2.3	3.76	3.2	3.63	4.0	3.53	4.9	3.42	5.8
		1550	4.63	1.7	4.47	2.6	4.30	3.6	4.17	4.5	4.07	5.5	3.96	6.5
		1700	5.17	1.9	5.01	2.9	4.84	4.0	4.71	5.0	4.61	6.1	4.50	7.2
BH100	4B	1100	4.34	1.8	4.16	2.6	4.00	3.4	3.85	4.3	3.71	5.3	3.57	6.3
		1300	5.32	2.2	5.15	3.0	4.99	4.0	4.84	5.1	4.70	6.3	4.56	7.4
		1450	6.04	2.4	5.87	3.4	5.71	4.5	5.56	5.7	5.42	7.0	5.29	8.3
		1550	6.52	2.6	6.35	3.6	6.19	4.8	6.04	6.1	5.90	7.5	5.77	8.9
		1750	7.45	3.1	7.28	4.2	7.12	5.6	6.97	7.0	6.83	8.6	6.70	10.1
		1950	8.36	3.4	8.19	4.7	8.03	6.2	7.88	7.9	7.74	9.6	7.61	11.4
BH125	5B	1100	6.65	2.4	6.45	3.7	6.25	5.0	6.05	6.4	5.85	7.9	5.65	9.5
		1300	8.19	2.9	7.99	4.3	7.79	5.9	7.59	7.6	7.39	9.4	7.19	11.2
		1450	9.35	3.2	9.15	4.8	8.95	6.5	8.75	8.5	8.55	10.5	8.35	12.5
		1550	10.1	3.4	9.92	5.1	9.72	7.0	9.52	9.1	9.32	11.2	9.12	13.4
		1750	11.7	4.0	11.5	5.9	11.3	8.1	11.1	10.4	10.9	12.8	10.7	15.3
1950	13.2	4.5	13.0	6.7	12.8	9.1	12.6	11.7	12.4	14.4	12.2	17.2		
BH125A	5B	1100	9.13	2.8	8.73	4.7	8.43	6.6	8.23	8.5	8.03	10.6	7.83	12.7
		1300	11.2	3.4	10.8	5.7	10.5	8.0	10.3	10.3	10.1	12.7	9.90	15.2
		1450	12.7	3.9	12.3	6.4	12.0	8.9	11.8	11.5	11.6	14.2	11.4	17.0
		1550	13.7	4.3	13.3	7.0	13.0	9.7	12.8	12.5	12.6	15.3	12.4	18.3
		1750	15.8	5.2	15.4	8.2	15.1	11.2	14.9	14.3	14.7	17.6	14.5	21.0
1950	17.9	6.1	17.5	9.4	17.2	12.8	17.0	16.3	16.8	19.9	16.6	23.7		
BH150	6B	900	14.0	4.4	13.6	6.8	13.3	9.4	13.0	12.2	12.7	15.1	12.4	18.1
		1050	16.8	5.3	16.4	8.3	16.1	11.3	15.8	14.5	15.5	17.9	15.2	21.5
		1150	18.6	5.8	18.2	9.1	17.9	12.4	17.6	15.9	17.3	19.6	17.0	23.5
		1250	20.5	6.6	20.1	10.0	19.8	13.7	19.5	17.5	19.2	21.5	18.9	25.7
		1400	23.2	7.6	22.8	11.5	22.5	15.6	22.2	19.9	21.9	24.4	21.6	29.1
1550	26.0	8.8	25.6	13.1	25.3	17.6	25.0	22.4	24.7	27.5	24.4	32.8		
BH150A	6B	900	20.0	7.0	18.7	10.6	17.5	14.1	16.5	18.2	15.5	22.3	14.7	26.4
		1050	23.8	8.2	22.5	12.4	21.4	16.5	20.4	21.3	19.2	26.0	18.6	30.8
		1150	26.3	9.0	25.0	13.6	23.8	18.0	22.8	23.3	21.8	28.5	21.0	33.8
		1250	28.9	9.8	27.6	14.8	26.4	19.6	25.4	25.3	24.4	31.0	23.6	36.7
		1400	32.8	10.9	31.5	16.5	30.3	21.9	29.3	28.4	28.3	34.7	27.5	41.1
1550	36.7	12.1	35.4	18.3	34.2	24.3	33.2	31.4	32.2	38.4	31.4	45.5		
BH200	8B	900	25.2	8.2	24.0	12.2	22.8	16.2	21.7	20.2	20.6	24.1	19.6	28.8
		1050	29.2	9.2	28.0	14.0	26.8	19.0	25.7	23.9	24.6	28.8	23.6	34.3
		1150	32.2	9.8	31.0	15.4	29.8	21.0	28.7	26.7	27.7	32.3	26.7	38.5
		1250	35.0	10.4	33.9	16.8	32.8	23.2	31.8	29.5	30.8	35.9	29.7	43.1
		1350	38.1	11.1	37.0	18.2	35.9	25.3	34.8	32.4	33.8	40.0	32.8	47.8
1450	41.2	11.9	40.0	19.7	38.8	27.5	37.8	35.4	36.7	43.0	35.9	52.5		
BH200A	8B	900	31.6	10.7	29.9	16.1	28.3	22.4	27.0	28.9	25.6	35.1	24.5	42.8
		1050	37.6	12.5	35.9	18.8	34.2	26.1	32.9	33.7	31.5	41.0	30.7	50.0
		1150	41.5	13.7	39.8	20.5	38.2	28.6	36.9	37.0	35.4	44.9	34.3	54.7
		1250	45.6	14.9	43.8	22.3	42.3	31.1	41.0	40.2	39.6	48.8	38.5	59.5
		1350	49.5	16.1	47.9	24.1	46.3	33.6	45.0	43.4	43.5	52.7	42.5	64.2
1450	53.5	17.3	51.8	25.9	50.2	36.1	48.9	46.6	47.5	56.6	46.4	69.0		
BH250	10B	800	34.7	9.5	34.1	16.4	33.5	23.3	32.9	30.2	32.3	37.1	31.7	44.0
		900	39.8	11.3	39.2	19.1	38.6	26.8	38.0	34.6	37.4	42.3	36.8	50.1
		1000	44.8	13.1	44.2	21.7	43.6	30.3	43.0	39.0	42.4	47.6	41.8	56.2
		1100	49.9	14.9	49.3	24.4	48.7	33.9	48.1	43.3	47.5	52.8	46.9	62.3
		1200	54.9	16.7	54.3	27.0	53.7	37.4	53.1	47.7	52.5	58.1	51.9	68.4
		1300	60.0	18.5	59.4	29.7	58.8	40.9	58.2	52.1	57.6	63.3	57.0	74.5
1400	65.0	20.3	64.4	32.4	63.8	44.4	63.2	56.5	62.6	68.5	62.0	80.6		



Model 型式	Bore 口径	min ⁻¹ 回転速度	10kPa (1020mmAq)		20kPa (2040mmAq)		30kPa (3060mmAq)		40kPa (4080mmAq)		50kPa (5100mmAq)		60kPa (6120mmAq)	
			m ³ /min	kW	m ³ /min	kW	m ³ /min	kW	m ³ /min	kW	m ³ /min	kW	m ³ /min	kW
BH250A	10B	800	49.1	24.8	47.8	33.5	46.8	42.2	45.9	50.8	45.2	59.5	44.5	68.1
		900	55.7	26.0	54.5	35.7	53.4	45.4	52.5	55.2	51.8	64.9	51.2	74.6
		1000	62.4	27.1	61.1	37.9	60.0	48.7	59.1	59.5	58.4	70.3	57.8	81.1
		1100	69.0	28.1	67.7	40.0	66.6	51.9	65.8	63.8	65.0	75.7	64.4	87.6
		1200	75.6	29.3	74.3	42.2	73.2	55.2	72.4	68.1	71.6	81.1	71.0	94.1
BH300	12B	800	51.6	16.5	48.6	26.5	46.6	37.0	44.6	46.5	42.6	55.5	40.6	68.0
		1000	67.0	20.6	64.0	33.1	62.0	46.3	60.0	58.0	58.6	69.4	56.0	85.0
		1200	82.3	24.8	79.3	39.8	77.3	55.5	75.3	69.8	73.3	83.3	71.3	102
		1400	97.7	28.9	94.7	46.4	92.7	64.8	90.7	81.4	88.7	97.1	86.7	119
		1500	105.3	30.9	102.3	49.7	100.3	69.4	98.3	87.2	96.3	104	94.3	128
BH350	14B	800	95.2	31.7	92.2	46.8	90.2	63.4	88.2	80.9	86.2	100	85.2	120
		900	108	35.7	105	52.6	103	71.3	101	91.0	99.1	113	98.1	135
		1000	121	39.6	118	58.5	116	79.2	114	101	112	125	111	150
		1100	134	43.6	131	64.3	129	87.2	127	111	125	138	124	165
		1200	147	47.5	144	70.2	142	95.1	140	121	138	150	137	180

section indicates water cooled housing and gear cover (coolant water volume: 15 to 25 L/min)
ギヤカバー・水冷式 (冷却水量15~25L/min)

Outline Drawing 外形寸法図

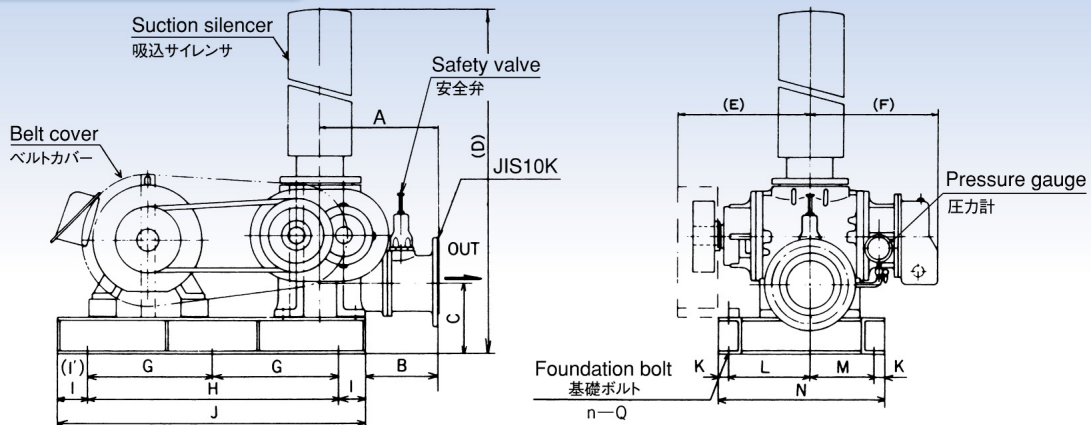

unit 単位: mm

Model 型式	Bore 口径	A	B	C	D	E	F	G	H	I (I')	J	K	L	M	N	n	Q	Weight (kg) 質量
BH 50	2B	165	100	120	980	250	230	—	460	50	560	20	190	130	360	4	M12	78
BH 65	2½B	165	100	129	1218	270	265	—	460	50	560	20	210	110	360	4	M12	105
BH 80	3B	262	152	155	1405	260	253	—	550	50	650	20	200	180	420	4	M12	135
BH100	4B	276	166	180	1477	320	288	—	600	50(100)	750	25	185	265	500	4	M12	145
BH125	5B	327	202	190	1712	365	350	—	650	100	850	35	220	240	530	4	M12	260
BH125A	5B	327	202	190	1712	415	400	—	650	100	850	35	270	260	600	4	M12	320
BH150	6B	412	252	235	1852	430	410	—	800	100	1000	35	270	260	600	4	M12	400
BH150A	6B	412	252	235	1852	500	480	—	1000	125	1250	35	340	360	770	4	M12	490
BH200	8B	482	302	255	2007	475	450	—	1000	125	1250	35	315	255	640	4	M12	640
BH200A	8B	482	297	255	2007	540	515	600	1200	100	1400	35	380	360	810	6	M12	780
BH250	10B	622	422	295	2117	580	515	600	1200	100	1400	35	375	305	750	6	M12	900
BH250A	10B	622	422	320	2142	650	590	750	1500	100	1700	35	450	430	950	6	M14	1100
BH300	12B	782	547	340	2581	645	625	800	1600	100	1800	35	600	530	1200	6	M16	1500
BH350	14B	800	550	390	2781	745	750	550	1650	100	1850	35	600	530	1200	8	M16	2400

- Weight shown covers the blower with standard accessories without motor
- Standard accessories: Suction silencer・Safety valve・V-pulley・V-belt・Pressure gauge・Base・Belt cover

Note : Please be aware that the size of the base may differ for special motors (special-configuration motors, heteroelectric motors, motors for exclusive use in inverters, etc.) as well as motors with slide bases.
Anti-vibration mounts, rubber vibration insulators, and intake silencers with attached air filters are available as options.

- 質量はモータを除いた標準付属品付の値です。※BE350の吸込サイレンサ形状は図とは異なります。
- 標準付属品: 吸込サイレンサ・圧力計・ベース・ベルトカバー・安全弁・Vプーリー・Vベルト・基礎ボルト
- (注) 特殊モータ (特殊形状モータ、異電圧モータ、インバータ専用モータ etc.) やスライドベース付モータの場合は、ベースの大きさが異なることもありますので、ご了承下さい。
防振架台・防振ゴム及びエアフィルタ付き吸込サイレンサも用意しております。(オプション)

BS Type

● Performance Chart 性能表 (1m³/min≒35.315CFM)

Model 型式	Bore 口径	min ⁻¹ 回転速度	10kPa (1020mmAq)		20kPa (2040mmAq)		30kPa (3060mmAq)		40kPa (4080mmAq)		50kPa (5100mmAq)		60kPa (6120mmAq)	
			m ³ /min	kW	m ³ /min	kW	m ³ /min	kW	m ³ /min	kW	m ³ /min	kW	m ³ /min	kW
BS 32	1 1/4B	1600	0.44	0.36	0.34	0.47	0.23	0.59						
		1750	0.54	0.41	0.44	0.54	0.34	0.68						
		1900	0.64	0.48	0.54	0.62	0.44	0.78	0.35	0.96				
		2050	0.74	0.55	0.64	0.71	0.54	0.89	0.45	1.10				
		2200	0.85	0.63	0.75	0.82	0.65	1.02	0.56	1.24	0.47	1.49		
BS 40	1 1/2B	1200	0.94	0.61	0.83	0.74	0.75	0.88	0.69	1.07	0.64	1.27		
		1300	1.04	0.67	0.93	0.82	0.85	0.98	0.79	1.20	0.73	1.41		
		1400	1.14	0.74	1.03	0.90	0.94	1.08	0.89	1.32	0.83	1.55	0.78	1.79
		1500	1.24	0.81	1.13	0.99	1.04	1.18	0.98	1.44	0.92	1.70	0.87	1.96
		1600	1.34	0.88	1.23	1.07	1.14	1.28	1.08	1.56	1.02	1.84	0.97	2.12
BS 50	2B	1000	1.30	0.7	1.15	0.9	1.03	1.3	0.94	1.5	0.85	1.9		
		1150	1.61	0.8	1.45	1.1	1.33	1.5	1.23	1.8	1.13	2.2		
		1250	1.81	0.9	1.65	1.2	1.52	1.6	1.43	2.0	1.32	2.4	1.28	2.9
		1400	2.11	1.0	1.94	1.4	1.81	1.9	1.72	2.3	1.61	2.7	1.56	3.3
		1500	2.31	1.1	2.14	1.5	2.01	2.0	1.91	2.4	1.80	2.9	1.75	3.6
BS 65	2 1/2B	1000	1.89	1.0	1.74	1.3	1.64	1.7	1.56	2.1	1.47	2.6	1.39	3.1
		1150	2.24	1.1	2.09	1.5	1.98	2.0	1.90	2.4	1.81	2.9	1.71	3.5
		1250	2.47	1.2	2.32	1.6	2.21	2.1	2.12	2.6	2.03	3.1	1.93	3.8
		1350	2.70	1.3	2.54	1.8	2.44	2.3	2.35	2.8	2.25	3.4	2.15	4.1
		1450	2.94	1.4	2.77	1.9	2.66	2.4	2.57	3.0	2.47	3.6	2.37	4.4
BS 80	3B	1000	3.28	1.6	3.11	2.3	3.02	2.9	2.91	3.6	2.86	4.1	2.66	5.0
		1100	3.69	1.8	3.52	2.5	3.42	3.2	3.31	4.0	3.26	4.6	3.05	5.6
		1200	4.10	2.0	3.92	2.8	3.83	3.6	3.71	4.5	3.66	5.1	3.45	6.1
		1300	4.52	2.2	4.33	3.1	4.23	3.9	4.12	4.9	4.06	5.5	3.84	6.7
		1350	4.73	2.2	4.54	3.2	4.44	4.1	4.32	5.1	4.26	5.8	4.04	7.0
BS 100	4B	1450	5.14	2.4	4.95	3.5	4.84	4.4	4.72	5.5	4.66	6.2	4.43	7.5
		1550	5.55	2.6	5.36	3.7	5.25	4.7	5.12	5.9	5.06	6.7	4.83	8.1
		900	5.05	2.3	4.64	3.3	4.36	4.4	4.12	5.4	3.89	6.4	3.72	7.4
		1000	5.93	2.7	5.35	3.8	5.02	5.0	4.80	6.2	4.58	7.3	4.39	8.5
		1100	6.59	3.0	6.06	4.3	5.73	5.7	5.48	7.0	5.28	8.3	5.07	9.6
BS125	5B	1200	7.48	3.4	6.77	4.8	6.34	6.3	6.16	7.8	5.97	9.2	5.75	10.7
		1300	8.15	3.7	7.48	5.3	7.05	7.0	6.85	8.6	6.67	10.2	6.43	11.8
		1400	8.82	4.0	8.19	5.8	7.75	7.6	7.49	9.4	7.26	11.1	7.10	12.9
		1450	9.27	4.2	8.62	6.1	8.15	7.9	7.82	9.8	7.59	11.6	7.44	13.5
		800	10.3	4.0	10.0	5.9	9.7	7.9	9.4	9.9	9.2	12.1	8.9	14.2
BS150	6B	900	11.7	4.5	11.5	6.7	11.1	9.0	10.8	11.3	10.6	13.8	10.3	16.2
		1000	13.2	5.1	12.9	7.6	12.6	10.1	12.3	12.7	12.0	15.5	11.7	18.2
		1100	14.7	5.6	14.4	8.4	14.0	11.2	13.7	14.1	13.4	17.2	13.1	20.2
		1200	16.1	6.2	15.8	9.3	15.4	12.3	15.2	15.5	14.9	19.0	14.5	22.2
		1300	17.6	6.8	17.3	10.1	16.9	13.4	16.6	16.8	16.3	20.7	15.9	24.2
BS200	8B	1350	18.3	7.0	18.0	10.5	17.6	14.0	17.3	17.5	17.0	21.5	16.6	25.2
		800	17.0	6.6	16.5	9.3	16.1	12.1	15.8	15.0	15.5	18.0	14.9	21.0
		900	19.3	7.7	18.8	10.8	18.4	14.1	18.1	17.6	17.8	21.0	17.2	24.5
		1000	21.7	8.8	21.1	12.4	20.8	16.1	20.4	20.1	20.1	24.0	19.4	28.1
		1050	22.9	9.4	22.3	13.2	21.9	17.1	21.5	21.3	21.2	25.5	20.6	29.8
BS200D	8B	1100	24.1	9.9	23.5	14.0	23.1	18.2	22.7	22.6	22.4	27.1	21.7	31.6
		1150	25.3	10.5	24.6	14.7	24.2	19.2	23.8	23.9	23.5	28.6	22.8	33.4
		1200	26.4	11.0	25.8	15.5	25.4	20.2	25.0	25.1	24.7	30.1	24.0	35.1
		1250	27.6	11.6	27.0	16.3	26.6	21.2	26.1	26.4	25.8	31.6	25.1	36.9
		700	28.5	11.6	27.8	15.3	27.1	19.6	26.7	24.6	26.4	30.1	26.1	36.0
BS200	8B	750	30.8	12.6	30.0	16.6	29.4	21.3	29.0	26.7	28.7	32.7	28.4	39.1
		800	33.1	13.6	32.3	18.0	31.7	23.0	31.3	28.9	31.0	35.3	30.7	42.2
		850	35.4	14.6	34.6	19.3	34.0	24.7	33.6	31.0	33.3	37.9	33.0	45.3
		900	37.6	15.6	36.9	20.6	36.3	26.4	35.9	33.1	35.6	40.5	35.3	48.4
		950	39.9	16.6	39.2	21.9	38.6	28.0	38.2	35.2	37.9	43.1	37.6	51.5
BS200D	8B	1000	42.2	17.6	41.5	23.2	40.9	29.7	40.5	37.3	40.2	45.7	39.9	54.6
		1050	44.5	18.6	43.8	24.5	43.2	31.4	42.8	39.4	42.5	48.3	42.2	57.7
		1100	46.8	19.9	46.1	26.3	45.5	33.7	45.1	42.2	44.8	51.7	44.5	61.8
		700	29.3	8.6	27.7	14.1	26.4	19.6	25.4	25.3	24.5	31.1	23.6	37.0
		750	31.6	9.2	30.0	15.1	28.7	21.0	27.7	27.1	26.8	33.3	25.9	39.6
BS200D	8B	800	34.0	9.8	32.4	16.1	31.1	22.4	30.1	29.0	29.2	35.5	28.3	42.3
		850	36.4	10.4	34.8	17.1	33.5	23.8	32.5	30.8	31.6	37.7	30.7	44.9
		900	38.7	11.1	37.1	18.1	35.8	25.2	34.8	32.6	33.9	39.9	33.0	47.5
		950	41.1	11.7	39.5	19.1	38.2	26.6	37.2	34.4	36.3	42.2	35.4	50.2
		1000	43.5	12.3	41.9	20.1	40.6	28.0	39.6	36.2	38.7	44.4	37.8	52.8
BS200D	8B	1050	45.8	12.9	44.2	21.1	42.9	29.4	41.9	38.0	41.0	46.6	40.1	55.5
		1100	48.2	13.5	46.6	22.1	45.3	30.8	44.3	39.8	43.4	48.8	42.5	58.1

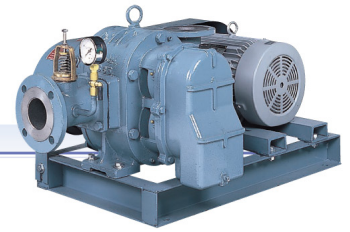

Model 型式	Bore 口径	min ⁻¹ 回転速度	10kPa (1020mmAq)		20kPa (2040mmAq)		30kPa (3060mmAq)		40kPa (4080mmAq)		50kPa (5100mmAq)		60kPa (6120mmAq)	
			m ³ /min	kW	m ³ /min	kW	m ³ /min	kW	m ³ /min	kW	m ³ /min	kW	m ³ /min	kW
BS250	10B	700	48.1	15.0	46.3	23.6	44.5	32.3	44.0	40.9	43.2	49.7	42.3	58.7
		750	52.0	16.2	50.2	25.5	48.4	34.9	48.0	44.3	47.1	53.7	46.2	63.5
		800	55.9	17.4	54.1	27.5	52.3	37.5	51.9	47.6	51.1	57.8	50.2	68.3
		850	59.8	18.6	58.1	29.4	56.3	40.2	55.9	50.9	55.0	61.8	54.1	73.1
		900	63.7	19.8	62.0	31.3	60.2	42.8	59.8	54.3	59.0	65.9	58.1	77.8
		950	67.6	21.1	65.9	33.2	64.1	45.4	63.7	57.6	62.9	69.9	62.0	82.6
		1000	71.5	22.3	69.8	35.2	68.1	48.1	67.7	61.0	66.9	74.0	66.0	87.4
		1050	75.4	23.5	73.7	37.1	72.0	50.7	71.6	64.3	70.8	78.0	69.9	92.2
BS250D	10B	700	61.2	19.7	58.9	31.1	56.9	42.6	55.1	54.2	53.4	66.7	51.9	79.6
		750	66.1	21.1	63.8	33.4	61.8	45.6	60.0	58.1	58.3	71.5	56.8	85.3
		800	71.1	22.6	68.8	35.6	66.8	48.7	65.0	61.9	63.3	76.3	61.8	91.0
		850	76.0	24.0	73.7	37.8	71.7	51.7	69.9	65.8	68.2	81.0	66.7	96.7
		900	81.0	25.4	78.7	40.0	76.7	54.8	74.9	69.7	73.2	85.8	71.7	102
		950	85.9	26.8	83.6	42.3	81.6	57.8	79.8	73.6	78.1	90.6	76.6	108
		1000	90.9	28.2	88.6	44.5	86.6	60.9	84.8	77.4	83.1	95.3	81.6	114
		1050	95.8	29.6	93.5	46.7	91.5	63.9	89.7	81.3	88.0	100	86.5	119
BS300	12B	700	82.7	24.3	79.7	39.4	77.3	54.9	75.3	70.5	73.6	86.4	72.0	103
		800	95.5	27.8	92.5	45.1	90.1	62.7	88.1	80.6	86.4	98.7	84.8	117
		850	101.9	29.5	98.9	47.9	96.5	66.7	94.5	85.6	92.8	105	91.2	125
		900	108.4	31.3	105.4	50.7	103.0	70.6	101.0	90.7	99.3	111	97.7	132
		950	114.8	33.0	111.8	53.5	109.4	74.5	107.4	95.7	105.7	117	104.1	139

● For the use at 60kPa or more, ask us for information. ● 60kPa以上で使用の際は、お問い合わせご相談下さい。

Outline Drawing 外形寸法図

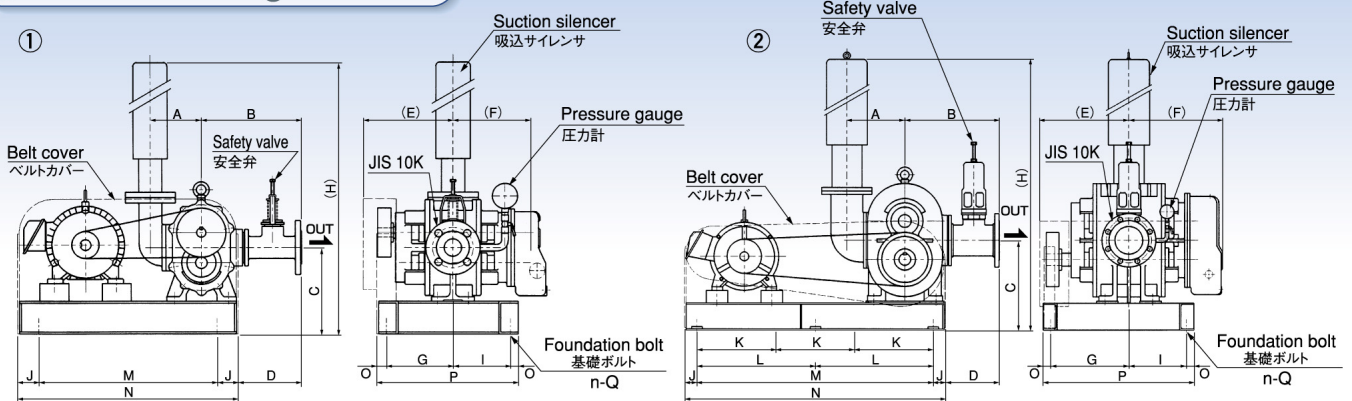

unit 単位 : mm

Model 型式	Bore 口径	A	B	C	D	E	F	G	H	I	J	K	L	M	N	O	P	Q	n	Weight (kg) 質量	No.
BS 32	1 1/4B	105	219	187	141	233	240	173	872	147	50	—	—	460	560	20	360	M12	4	56	①
BS 40	1 1/2B	132	260	224	170	232	242	172	1004	148	50	—	—	460	560	20	360	M12	4	88	
BS 50	2B	144	250	224	147	305	307	255	1222	150	50	—	—	620	720	20	445	M12	4	132	
BS 65	2 1/2B	180	301	258	181	280	291	230	1275	175	50	—	—	620	720	20	445	M12	4	160	
BS 80	3B	180	325	283	197	347	347	302	1470	198	100	—	—	670	870	25	550	M12	4	217	
BS100	4B	214	374	324	224	390	404	325	1577	205	100	—	—	760	960	35	600	M12	4	327	
BS125	5B	271	442	420	259	415	431	365	1907	265	50	—	550	1100	1200	35	700	M14	6	530	
BS150	6B	306	490	459	285	445	525	395	1961	335	100	—	550	1100	1300	35	800	M14	6	690	
BS200	8B	392	616	539	376	510	550	465	2123	415	100	—	750	1500	1700	35	950	M16	6	1169	
BS200D	8B	440	677	585	407	525	585	475	2287	405	100	—	750	1500	1700	35	950	M16	6	1521	
BS250	10B	440	758	584	489	686	733	651	2238	479	100	—	800	1600	1800	35	1200	M18	6	1904	
BS250D	10B	700	842	692	517	720	775	660	2650	670	105	630	—	1890	2100	35	1400	M18	8	2420	
BS300	12B	700	797	692	472	813	850	753	2650	577	105	630	—	1890	2100	35	1400	M18	8	2950	

● Weight shown covers the blower with standard accessories without motor
 ● Standard accessories: Suction silencer·Safety valve·V-pulley·V-belt·Pressure gauge·Base·Belt cover
 Note : Please be aware that the size of the base may differ for special motors (special-configuration motors, heteroelectric motors, motors for exclusive use in inverters, etc.) as well as motors with slide bases.
 Anti-vibration mounts, rubber vibration insulators, and intake silencers with attached air filters are available as options.

● 質量はモータを除いた標準付属品付の値です。
 ● 標準付属品：吸込サイレンサ・圧力計・ベース・ベルトカバー・安全弁・Vプーリー・Vベルト・基礎ボルト
 (注) 特殊モータ(特殊形状モータ、異電圧モータ、インバータ専用モータ etc.) やスライドベース付モータの場合は、ベースの大きさが異なることもありますので、ご了承下さい。
 防振架台・防振ゴム及びエアフィルタ付き吸込サイレンサも用意しております。(オプション)

BWH Type

● Performance Chart 性能表 (1m³/min≒35.315CFM)

Frequency 周波数 Hz	Model 型式	Bore 口径	Submersible motor 3-phase/ 200V×4P 水中モーター 3相	Standard suction state air capacity (m ³ /min) and power requirements (kW) 標準吸込状態空気量 (m ³ /min) および所要動力 (kW)											
				10kPa (1020mmAq)		20kPa (2040mmAq)		30kPa (3060mmAq)		40kPa (4080mmAq)		50kPa (5100mmAq)		60kPa (6120mmAq)	
				m ³ /min	kW	m ³ /min	kW	m ³ /min	kW	m ³ /min	kW	m ³ /min	kW	m ³ /min	kW
50	BWH2504	25A (1B)	0.4kW	0.31	0.23	0.28	0.27	0.25	0.31	0.22	0.35	0.19	0.40		
	BWH2504A	25A (1B)	0.4kW	0.39	0.28	0.35	0.33	0.31	0.38						
	BWH3208	32A (1¼B)	0.75kW	0.56	0.38	0.49	0.44	0.42	0.50	0.36	0.56	0.30	0.63		
	BWH3208A	32A (1¼B)	0.75kW	0.69	0.39	0.61	0.45	0.53	0.53	0.46	0.62	0.40	0.73		
	BWH4015	40A (1½B)	1.5kW	0.99	0.60	0.88	0.78	0.77	0.96	0.67	1.16	0.58	1.38		
	BWH4015D	40A (1½B)	1.5kW	1.15	0.70	1.05	0.90	0.95	1.10	0.87	1.30				
	BWH4022	40A (1½B)	2.2kW	1.18	0.72	1.07	0.92	0.98	1.12	0.91	1.32	0.85	1.52	0.80	1.75
	BWH5015	50A (2B)	1.5kW	1.15	0.70	1.05	0.90	0.95	1.10	0.87	1.30				
	BWH5022	50A (2B)	2.2kW	1.48	0.81	1.33	1.06	1.18	1.31	1.05	1.61	0.93	1.93		
	BWH5022D	50A (2B)	2.2kW	2.10	1.0	1.98	1.4	1.87	1.8	1.78	2.2				
	BWH5037	50A (2B)	3.7kW	2.20	1.5	2.06	1.9	1.92	2.2	1.81	2.6	1.72	3.1	1.65	3.6
	BWH6522	65A (2½B)	2.2kW	2.10	1.0	1.98	1.4	1.87	1.8	1.78	2.2				
	BWH6537	65A (2½B)	3.7kW	3.06	1.6	2.88	1.9	2.70	2.4	2.54	2.9	2.40	3.6		
	BWH6537A	65A (2½B)	3.7kW	3.90	1.8	3.70	2.3	3.50	2.9	3.31	3.7				
	BWH6555	65A (2½B)	5.5kW	3.06	1.6	2.88	1.9	2.70	2.4	2.54	2.9	2.40	3.6	2.31	4.3
	BWH8055	80A (3B)	5.5kW	4.56	2.0	4.28	2.8	4.00	3.6	3.75	4.3	3.50	5.5		
	BWH8075	80A (3B)	7.5kW	5.30	2.2	5.05	3.1	4.80	4.0	4.50	5.1	4.31	6.2	4.11	7.3
	BWH10075	100A (4B)	7.5kW	6.4	2.8	6.2	3.9	6.0	5.0	5.8	6.2	5.6	7.5		
BWH10011	100A (4B)	11kW	6.4	2.8	6.2	3.9	6.0	5.0	5.8	6.2	5.6	7.5	5.4	9.0	
BWH12575	125A (5B)	7.5kW	6.4	2.8	6.2	3.9	6.0	5.0	5.8	6.2	5.6	7.5			
BWH12511	125A (5B)	11kW	9.6	3.7	9.3	5.5	9.0	7.3	8.8	9.2	8.6	11.0			
BWH12515	125A (5B)	15kW	9.6	3.7	9.3	5.5	9.0	7.3	8.8	9.2	8.6	11.0	8.4	13.1	
60	BWH2504	25A (1B)	0.4kW	0.40	0.24	0.36	0.31	0.32	0.38						
	BWH3208	32A (1¼B)	0.75kW	0.69	0.39	0.61	0.45	0.53	0.53	0.46	0.62	0.40	0.72		
	BWH4015	40A (1½B)	1.5kW	1.23	0.66	1.13	0.88	1.03	1.10	0.93	1.36				
	BWH4015D	40A (1½B)	1.5kW	1.42	0.72	1.32	0.91	1.22	1.19	1.14	1.50				
	BWH4022	40A (1½B)	2.2kW	1.43	0.74	1.33	0.93	1.25	1.21	1.18	1.51	1.11	1.83	1.05	2.18
	BWH5015	50A (2B)	1.5kW	1.42	0.72	1.32	0.91	1.22	1.19	1.14	1.50				
	BWH5022	50A (2B)	2.2kW	1.83	0.84	1.70	1.10	1.53	1.50	1.40	1.95				
	BWH5022D	50A (2B)	2.2kW	2.52	1.3	2.40	1.7	2.28	2.2						
	BWH5037	50A (2B)	3.7kW	2.70	1.9	2.56	2.4	2.42	2.8	2.31	3.2	2.20	3.7		
	BWH6522	65A (2½B)	2.2kW	2.52	1.3	2.40	1.7	2.28	2.2						
	BWH6537	65A (2½B)	3.7kW	3.76	2.0	3.58	2.3	3.40	2.9	3.24	3.7				
	BWH6555	65A (2½B)	5.5kW	3.76	2.0	3.58	2.3	3.40	2.9	3.24	3.7	3.12	4.5	3.01	5.4
	BWH8055	80A (3B)	5.5kW	5.70	2.3	5.50	3.3	5.30	4.3	5.10	5.5				
	BWH8075	80A (3B)	7.5kW	6.51	2.5	6.26	3.6	6.01	4.9	5.78	6.1	5.60	7.4		
	BWH10075	100A (4B)	7.5kW	7.6	3.1	7.4	4.6	7.2	6.1	7.0	7.5				
	BWH10011	100A (4B)	11kW	7.6	3.1	7.4	4.6	7.2	6.1	7.0	7.5	6.8	9.1	6.6	11.0
	BWH12575	125A (5B)	7.5kW	7.6	3.1	7.4	4.6	7.2	6.1	7.0	7.5				
	BWH12511	125A (5B)	11kW	11.4	4.4	11.1	6.6	10.8	8.8	10.5	11.0				
BWH12515	125A (5B)	15kW	11.4	4.4	11.1	6.6	10.8	8.8	10.5	11.0	10.2	13.0	9.8	15.0	

● Outline Drawing 外形寸法図

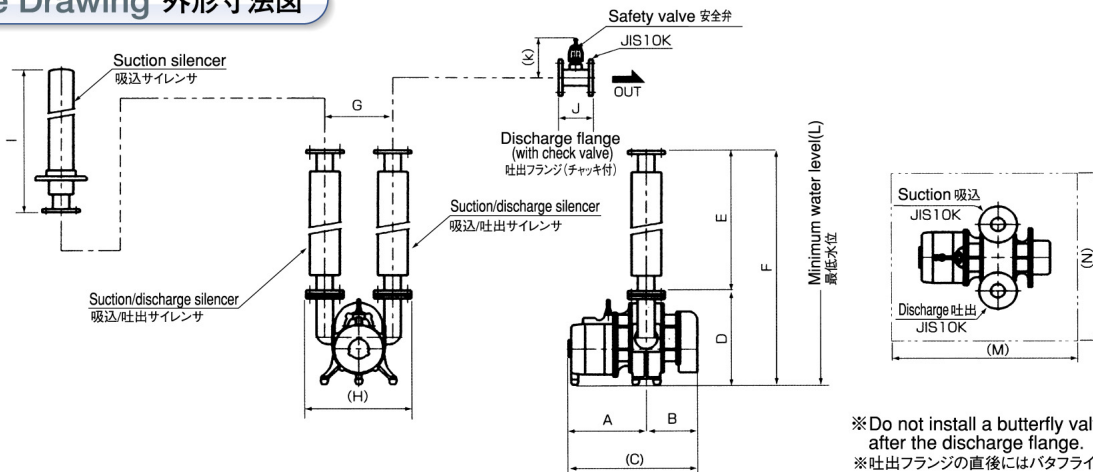

※ Do not install a butterfly valve immediately after the discharge flange.
 ※ 吐出フランジの直後にはバタフライ弁を付けないで下さい。



Dimensions Table 寸法表

unit 単位 : mm

Model 型式	Bore 口径	A	B	C	D	E	F	G	H	I	J	K	L	N	Cab tire cable キャブタイヤケーブル	Weight (kg) 質量
BWH2504	25A (1B)	228	133	361	276	414	690	176	301	580	130	140	500	700×500 or φ600	1.25mm ² ×6m	56
BWH2504A	25A (1B)	243	148	391	276	414	690	176	301	580	130	140	500			59
BWH3208	32A (1¼B)	257	148	405	292	418	710	192	327	580	135	145	550			69
BWH3208A	32A (1¼B)	272	163	435	292	418	710	192	327	580	135	145	550			74
BWH4015	40A (1½B)	296	183	479	324	578	902	240	380	650	150	145	650	700×500 or φ900	1.25mm ² ×10m	107
BWH4015D	40A (1½B)	306	193	499	324	578	902	240	380	650	150	145	650			110
BWH4022	40A (1½B)	343	193	536	324	578	902	240	380	650	150	145	650			113
BWH5015	50A (2B)	306	193	499	324	815	1139	240	395	870	150	150	750	900×600 or φ900	1.25mm ² ×10m	126
BWH5022	50A (2B)	363	213	576	324	815	1139	240	395	870	150	150	750			137
BWH5022D	50A (2B)	343	216	559	398	815	1213	312	467	870	150	150	850			166
BWH5037	50A (2B)	337	223	560	398	815	1213	298	453	870	150	150	850			161
BWH6522	65A (2½B)	342	217	559	398	785	1183	312	487	870	160	160	850	900×600	2mm ² ×10m	174
BWH6537	65A (2½B)	355	240	595	408	785	1193	317	492	870	160	160	850		1.25mm ² ×10m	190
BWH6537A	65A (2½B)	375	260	635	408	785	1193	317	492	870	160	160	850		2mm ² ×10m	196
BWH6555	65A (2½B)	369	240	609	435	785	1220	317	492	870	160	160	900	900×600	3.5mm ² ×10m	205
BWH8055	80A (3B)	407	278	685	445	900	1345	332	517	1120	190	200	950		251	
BWH8075	80A (3B)	459	295	754	445	900	1345	332	517	1120	190	200	950	1200×800	5.5mm ² ×10m	268
BWH10075	100A (4B)	424	255	679	425	900	1325	420	630	1120	200	210	950		313	
BWH10011	100A (4B)	452	255	707	445	900	1345	420	630	1120	200	210	950		5.5mm ² ×10m	363
BWH12575	125A (5B)	424	255	679	425	1000	1425	460	710	1215	200	225	1000	1200×800	2—5.5mm ² ×10m	363
BWH12511	125A (5B)	502	305	807	445	1000	1445	460	710	1215	200	225	1000		5.5mm ² ×10m	413
BWH12515	125A (5B)	552	305	857	445	1000	1445	460	710	1215	200	225	1000		2—8mm ² ×10m	423

(Mass value includes standard accessories.)
(質量は標準付属品を含んでいます)

- Direct startup with 7.5 kW or smaller models; star-delta startup with 11.15 kW model.
- Standard accessories: Suction silencer · Suction/discharge silencer · Safety valve · Pressure gauge · Discharge flange (with check valve) · Hoisting chain (6 m) (4015~12515) · Rubber cushion
- 起動方式は7.5kW以下がダイレクト起動、11・15kWはスターデルタ起動です。
- 標準付属品：吸込サイレンサ・吸込吐出サイレンサ・安全弁・圧力計・吐出フランジ(チャッキ付)・吊り上げチェーン6m(4015~12515)・防振ゴム

Typical installation 設置例

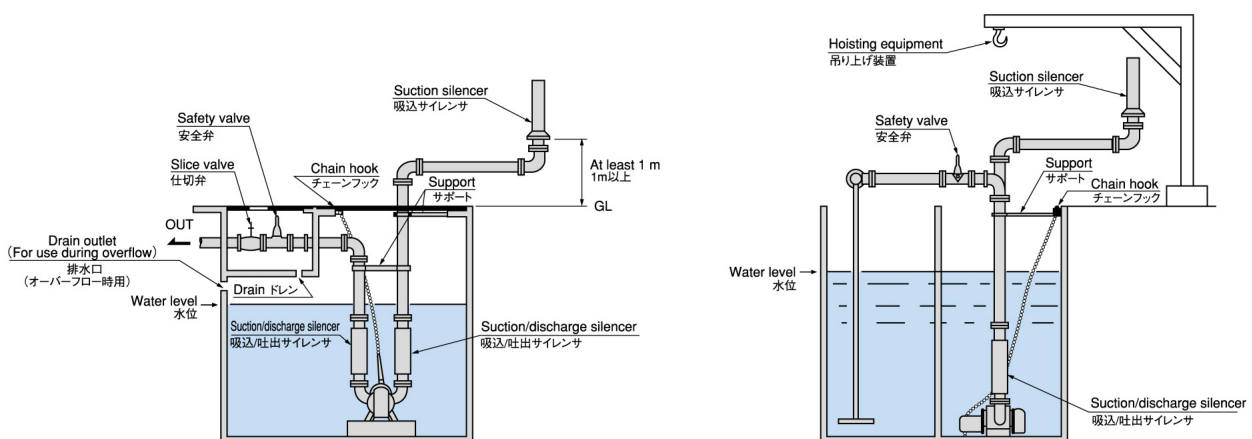

- Install the suction silencer outside of the tank (at least 1 m above ground).
- The safety valve part must be above the maximum water level (at least 1 m away from the tank).
- Use steel pipe.
- Tank opening must be larger than the blower.
- Provide supports for piping.
- Provide a drain hole so that water will drain out even if the water level rises abnormally.
- If the safety valve is installed as shown in the figure, provide a drain hole so that rainwater does not accumulate.
- Make sure the hoisting chain does not contact any piping.
(Prevent contact between chain and piping due to water splashing during aeration.)
- Install the suction silencer outdoors if an underground septic tank is provided.

- 吸込サイレンサは槽外へ。(地面より1m以上高く)
- 安全弁部は最高水位より高く。(1m以上離す)
- 配管は鋼管で。
- 槽開口部はブローより大きく。
- 配管サポートをつける。
- 水位が異常上昇してもよいように排水口を備える。
- 安全弁を図の様にした場合、雨水がたまらないようドレン穴を備える。
- 吊り上げ用チェーンは配管に触れないようにする。
(バッキ時の水揺れにより、チェーンと配管が接触するのを防ぐため)
- 地下式浄化槽の場合は吸込サイレンサは屋外に設置する。

BSS Type



● Performance Chart 性能表 (1m³/min≒35.315CFM)

Model 型式	Bore 口径	min ⁻¹ 回転速度	10kPa (1020mmAq)		20kPa (2040mmAq)		30kPa (3060mmAq)		40kPa (4080mmAq)		50kPa (5100mmAq)	
			m ³ /min	kW	m ³ /min	kW	m ³ /min	kW	m ³ /min	kW	m ³ /min	kW
BSS20	3/4 B	1750	0.24	0.25	0.21	0.29	0.18	0.33	0.15	0.38	0.12	0.45
		2000	0.30	0.28	0.27	0.33	0.24	0.38	0.21	0.44	0.18	0.51
BSS25	1 B	2300	0.36	0.32	0.33	0.38	0.30	0.44	0.27	0.51	0.24	0.58
		2600	0.43	0.36	0.40	0.42	0.37	0.49	0.34	0.57	0.31	0.66
		3000	0.52	0.42	0.49	0.49	0.46	0.57	0.43	0.66	0.40	0.76
BSS32	1 1/4 B	2300	0.57	0.46	0.53	0.54	0.49	0.63	0.45	0.73	0.41	0.84
		2600	0.67	0.52	0.63	0.61	0.59	0.71	0.55	0.82	0.51	0.94
		3000	0.80	0.60	0.76	0.70	0.72	0.82	0.68	0.95	0.64	1.09
BSS40	1 1/2 B	2300	0.81	0.63	0.76	0.74	0.71	0.87	0.66	1.01	0.61	1.15
		2600	0.94	0.71	0.89	0.84	0.84	0.99	0.79	1.14	0.74	1.30
		3000	1.12	0.82	1.07	0.97	1.02	1.14	0.97	1.32	0.92	1.50

● Outline Drawing 外形寸法図

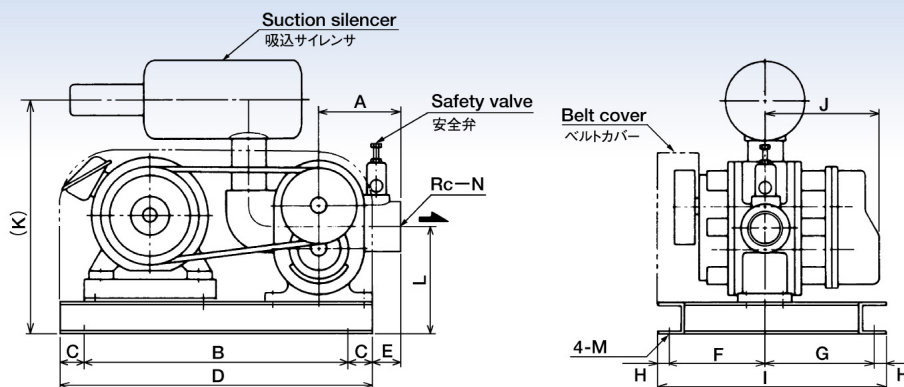

unit 単位 : mm

Model 型式	Bore 口径	A	B	C	D	E	F	G	H	I	J	K	L	M	N	Weight (kg) 質量
BSS20	3/4 B	95	350	25	400	25	110	164	13	300	143	310	133	12	3/4"	18
BSS25	1 B	95	350	25	400	25	110	164	13	300	143	310	133	12	1"	18
BSS32	1 1/4 B	95	350	25	400	25	122	152	13	300	155	325	133	12	1 1/4"	20
BSS40	1 1/2 B	95	350	25	400	25	137	137	13	300	170	350	133	12	1 1/2"	23

- Weight shown covers the blower with standard accessories without motor
- Standard accessories: Suction silencer・Safety valve・V-pulley・V-belt・Base・Belt cover
- 質量はモータを除いた標準付属品付の値です。
- 標準付属品：吸込サイレンサ・ベース・ベルトカバー・安全弁・Vプーリ・Vベルト

AAB (Air blow package) (エアブローパッケージ) Type



Performance Chart 性能表 (1m³/min≒35.315CFM)

Model 型式	Bore 口径	Motor output モーター 3相200V Three phase, 200V (kW)	Air capacity 空気量 at 20kPa (m ³ /min)	MAX working pressure 最高使用圧力 (kPa)
AAB37	50A	3.7	3.4	40
AAB55	65A	5.5	4.9	
AAB75	80A	7.5	7.2	
AAB100	100A	11	10.2	

Performance curve 性能曲線

Air capacity 空気量

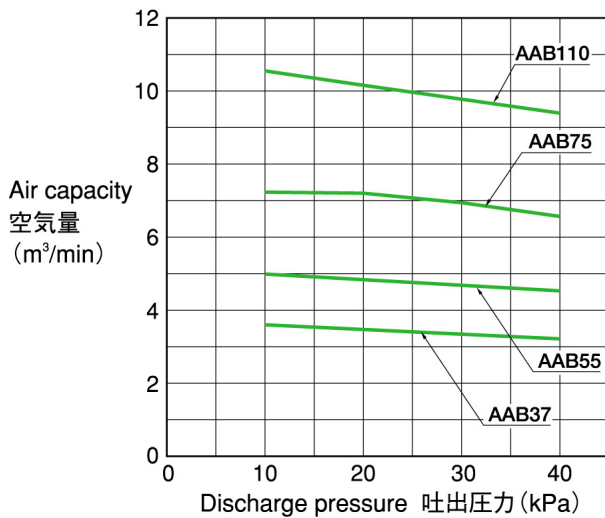

Required power 所要動力

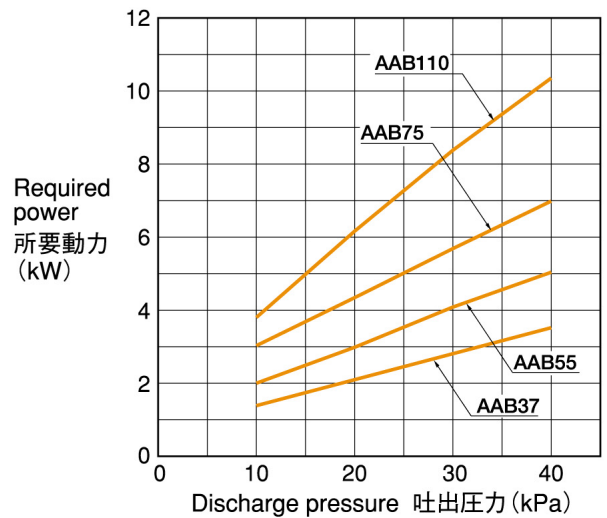

Outline Drawing 外形寸法図

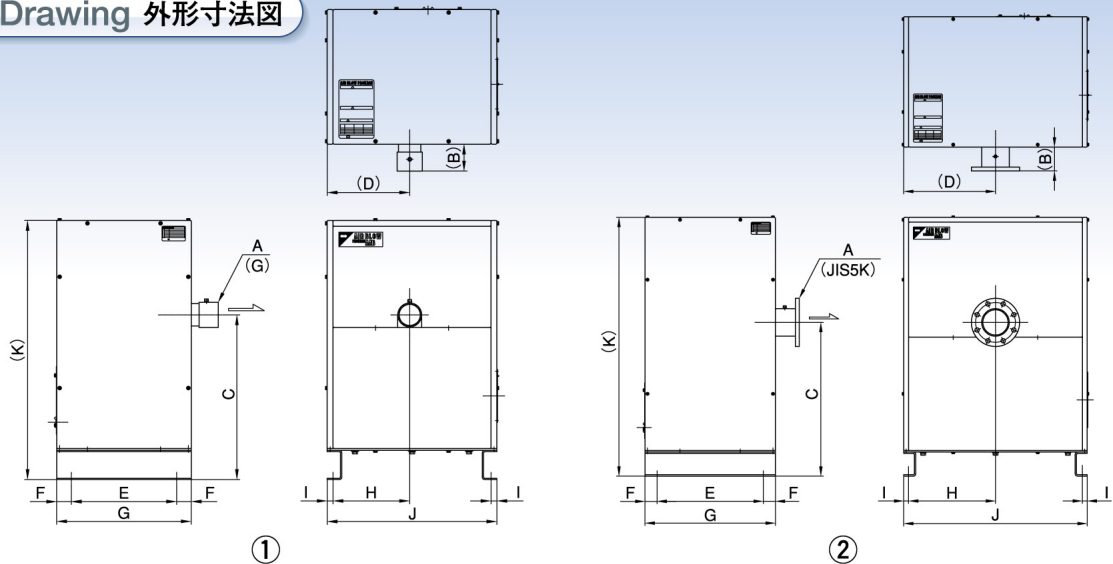

unit 単位 : mm

Model 型式	A	B	C	D	E	F	G	H	I	J	K	Weight (kg) 質量	No.
AAB37	50	82	497	245	320	50	420	225	20	510	813	135	①
AAB55	65	92	563	282	360	50	460	262	20	580	893	180	①
AAB75	80	101	573	272	385	50	485	252	20	580	1003	240	②
AAB110	100	99	637	380	440	50	540	360	20	760	1079	335	②

- Standard accessories: Suction silencer・V-pulley・V-belt・Panel base・Brower base・Soundproof panel・Three-phase, totally enclosed, fan-cooled
- Mass value includes standard accessories.

- 標準付属品: 吸込サイレンサ・Vプーリー・Vベルト・パネルベース・ブロワベース・防音パネル・全閉外扇モータ (3相200V)
- 質量は標準付属品付きの概略値です。

BS-V (Dry vacuum type blower) (乾式真空用ブロワ) Type

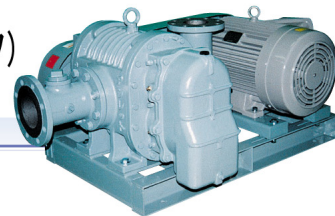

Performance Chart 性能表 (1m³/min≒35.315CFM)

Model 型式	Bore 口径	min ⁻¹ 回転速度	Standard suction state air capacity (m ³ /min) and power requirements (kW) 標準吸込状態空気量 (m ³ /min) および所要動力 (kW)										Cooling fan three phase, 200v 冷却ファン 3相・200V W
			-20kPa (-2040mmAq)		-30kPa (-3060mmAq)		-40kPa (-4080mmAq)		-50kPa (-5100mmAq)		-60kPa (-6120mmAq)		
			m ³ /min	kW	m ³ /min	kW	m ³ /min	kW	m ³ /min	kW	m ³ /min	kW	
BS65V	65A (2½B)	1250	2.57	1.9	2.42	2.5	2.26	2.9	2.09	3.4	1.84	3.8	50
		1350	2.82	2.0	2.67	2.7	2.51	3.2	2.34	3.7	2.09	4.1	
		1400	2.95	2.1	2.80	2.8	2.64	3.3	2.47	3.8	2.22	4.2	
		1550	3.33	2.3	3.18	3.1	3.02	3.6	2.85	4.2	2.60	4.7	
		1750	3.84	2.6	3.69	3.4	3.53	4.1	3.36	4.7	3.11	5.3	
		2000	4.48	3.0	4.33	3.9	4.17	4.6	4.00	5.4	3.75	6.0	
BS80V	80A (3B)	1250	5.15	2.7	4.66	3.7	4.45	4.6	4.16	5.6	3.78	6.5	50
		1350	5.61	2.9	5.12	4.0	4.91	5.0	4.61	6.0	4.23	7.0	
		1550	6.52	3.3	6.03	4.5	5.82	5.7	5.52	6.9	5.15	8.1	
		1750	7.43	3.8	6.94	5.1	6.73	6.5	6.43	7.8	6.06	9.2	
		2000	8.57	4.3	8.08	5.8	7.87	7.4	7.57	8.9	7.19	10.5	
		2200	9.48	4.7	8.99	6.4	8.78	8.1	8.48	9.8	8.11	11.5	
BS100V	100A (4B)	1300	8.6	5.4	8.5	7.0	8.3	8.6	8.0	10.4	7.7	12.1	50
		1550	10.5	6.4	10.4	8.3	10.2	10.3	9.9	12.4	9.6	14.4	
		1750	12.1	7.2	12.0	9.4	11.8	11.6	11.4	14.0	11.1	16.3	
		1850	12.8	7.6	12.7	9.9	12.5	12.3	12.2	14.8	11.9	17.2	
		2000	14.0	8.2	13.9	10.8	13.7	13.3	13.4	16.0	13.1	18.6	
BS125V	125A (5B)	1150	16.8	8.2	16.4	11.3	15.9	14.4	14.8	17.6	13.7	20.8	200
		1300	19.1	9.2	18.7	12.8	18.2	16.3	17.1	20.0	16.0	23.5	
		1550	23.0	11.0	22.6	15.2	22.1	19.4	21.0	23.7	19.9	28.0	
		1750	26.0	12.5	25.6	17.2	25.1	21.9	24.0	26.8	22.9	31.7	
		1950	29.1	13.9	28.7	19.2	28.2	24.5	27.1	29.9	26.0	35.4	
		2100	31.4	14.9	31.0	20.7	30.5	26.4	29.4	32.1			
BS150V	150A (6B)	1150	26.6	13.0	26.3	18.0	26.0	23.0	24.3	28.1	22.2	33.7	200
		1300	30.4	14.7	30.1	20.3	29.8	26.0	28.1	31.8	26.0	38.1	
		1550	36.6	17.6	36.3	24.3	36.0	31.0	34.3	37.9	32.2	45.4	
		1750	41.6	19.8	41.3	27.4	41.0	35.0	39.3	42.8	37.2	51.3	
		1950	46.7	22.1	46.4	30.5	46.1	39.0	44.4	47.7			

Outline Drawing 外形寸法図

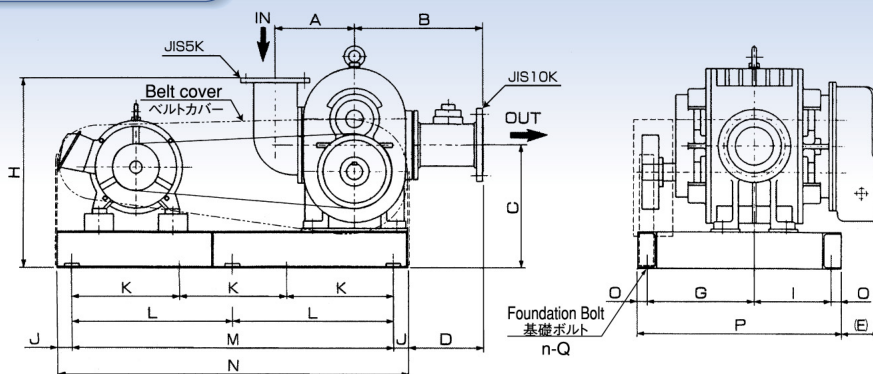

unit 単位 : mm

Model 型式	A	B	C	D	E	G	H	I	J	L	M	N	O	P	n	Q	Weight (kg) 質量
BS65V	180	301	258	181	96	230	403	175	50	—	620	720	20	445	4	M12	135
BS80V	180	325	283	197	124	302	448	198	100	—	670	870	25	550	4	M12	177
BS100V	214	374	324	224	164	325	514	205	100	—	760	960	35	600	4	M12	267
BS125V	271	441	420	259	131	365	650	265	50	550	1100	1200	35	700	6	M14	423
BS150V	306	490	459	285	155	395	704	335	100	550	1100	1300	35	800	6	M14	645

- Weight shown covers the blower with standard accessories without motor
- Standard accessories: Base·Belt cover·V-pulley·V-belt·Vacuum gauge·Vacuum safety valve·Foundation bolt
- 質量はモータを除いた標準付属品付の値です。
- 標準付属品: ベース・ベルトカバー・Vプーリー・Vベルト・真空計・真空安全弁・基礎ボルト

* If pressure is over -50kPa or applied the region of it must add the cooling fan.
 * The case of putting the delivery silencer (For atmosphere relief), pressure loss is considered and select the motor electric power.

※ 圧力-50kPa (-375mmHg) を越える場合及び の範囲は冷却ファン付きとなります。
 ※ 放出サイレンサを付ける場合はサイレンサ圧損を考慮してモータ出力を選定して下さい。

BE-H (Dry vacuum type blower) (乾式真空用ブロワ) Type

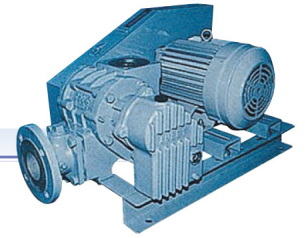

Performance Chart 性能表 (1m³/min≒35.315CFM)

Model 型式	Bore 口径	min ⁻¹ 回転速度	Standard suction state air capacity (m³/min) and power requirements (kW) 標準吸込状態空気量 (m³/min) および所要動力 (kW)									
			-10kPa (-1020mmAq)		-20kPa (-2040mmAq)		-30kPa (-3060mmAq)		-40kPa (-4080mmAq)		-50kPa (-5100mmAq)	
			m³/min	kW	m³/min	kW	m³/min	kW	m³/min	kW	m³/min	kW
BE65H	65A (2 1/2 B)	2100	2.54	0.9	2.44	1.4	2.33	1.9	2.21	2.4	2.08	2.9
		2350	2.89	1.0	2.79	1.6	2.68	2.1	2.56	2.7	2.43	3.2
		2450	3.03	1.1	2.93	1.6	2.82	2.2	2.70	2.8	2.57	3.4
		2600	3.24	1.1	3.14	1.7	3.03	2.3	2.91	2.9	2.78	3.6
		2750	3.45	1.2	3.35	1.8	3.24	2.5	3.12	3.1	2.99	3.8
		2900	3.66	1.3	3.56	1.9	3.45	2.6	3.33	3.3	3.20	4.0
		3250	4.15	1.4	4.05	2.2	3.94	2.9	3.82	3.7	3.69	4.4
BE80H	80A (3B)	2100	4.17	1.3	4.04	2.1	3.90	2.9	3.75	3.6	3.59	4.4
		2350	4.61	1.5	4.48	2.4	4.34	3.2	4.19	4.1	4.03	4.9
		2450	4.83	1.6	4.70	2.5	4.56	3.4	4.41	4.3	4.25	5.2
		2600	5.16	1.7	5.03	2.6	4.89	3.6	4.74	4.5	4.58	5.5
		2750	5.49	1.7	5.36	2.8	5.22	3.8	5.07	4.8	4.91	5.8
		2900	5.82	1.8	5.69	2.9	5.55	4.0	5.40	5.0	5.24	6.1
		3250	6.59	2.1	6.46	3.3	6.32	4.5	6.17	5.6	6.01	6.8
BE100H	100A (4B)	2050	5.96	2.1	5.79	3.2	5.61	4.3	5.42	5.4	5.22	6.6
		2150	6.28	2.2	6.11	3.3	5.93	4.5	5.74	5.7	5.54	6.9
		2300	6.77	2.3	6.60	3.6	6.42	4.8	6.23	6.1	6.03	7.4
		2400	7.09	2.4	6.92	3.7	6.74	5.0	6.55	6.4	6.35	7.7
		2700	8.05	2.7	7.88	4.2	7.70	5.7	7.51	7.2	7.31	8.6
		2900	8.69	2.9	8.52	4.5	8.34	6.1	8.15	7.7	7.95	9.3
		3050	9.17	3.1	9.00	4.7	8.82	6.4	8.63	8.1	8.43	9.8
BE125H	125A (5B)	1750	9.9	2.7	9.5	4.5	9.1	6.4	8.7	8.3	8.2	10.2
		1950	11.1	3.0	10.7	5.0	10.3	7.1	9.9	9.3	9.4	11.4
		2150	12.3	3.3	11.9	5.5	11.5	7.8	11.1	10.2	10.6	12.5
		2400	13.8	3.7	13.4	6.2	13.0	8.8	12.6	11.4	12.1	14.0
		2700	15.6	4.1	15.2	7.0	14.8	9.8	14.4	12.8	13.9	15.7
		2900	16.8	4.4	16.4	7.5	16.0	10.5	15.6	13.7	15.1	16.9
		3050	17.7	4.7	17.3	7.9	16.9	11.2	16.5	14.5	16.0	17.8
BE150H	150A (6B)	1550	18.4	5.4	17.7	8.7	17.1	11.9	16.4	15.1	15.7	18.4
		1700	20.3	5.9	19.6	9.5	19.0	13.0	18.3	16.6	17.6	20.2
		1800	21.6	6.3	20.9	10.1	20.3	13.8	19.6	17.6	18.9	21.4
		1950	23.5	6.8	22.8	10.9	22.2	15.0	21.5	19.1	20.8	23.2
		2100	25.4	7.4	24.7	11.8	24.1	16.2	23.4	20.6	22.7	25.0
		2250	27.4	7.8	26.7	12.6	26.1	17.3	25.4	22.0	24.7	26.7
		2550	31.2	8.9	30.5	14.3	29.9	19.6	29.2	24.9	28.5	30.3

Outline Drawing 外形寸法図

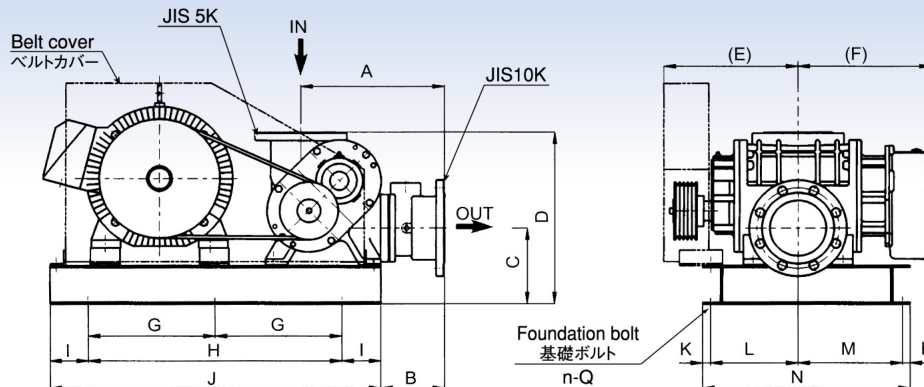

unit 単位 : mm

Model 型式	A	B	C	D	E	F	G	H	I	J	K	L	M	N	n	Q	Weight (kg) 質量
BE65H	272	132	142	322	225	220	—	550	50	650	18	128	171	335	4	M12	75
BE80H	277	122	152	332	270	257	—	600	50	700	18	164	250	450	4	M12	101
BE100H	342	153	187	442	250	275	—	600	100	800	20	133	312	485	4	M12	135
BE125H	367	163	197	447	345	345	—	650	100	850	20	223	267	530	4	M12	169
BE150H	412	178	212	502	475	455	—	850	100	1050	20	320	220	580	4	M12	296

- Weight shown covers the blower with standard accessories without motor
- Standard accessories: Base・Belt cover・V-pulley・V-belt・Foundation bolt

- 質量はモータを除いた標準付属品付の値です。
- 標準付属品: ベース・ベルトカバー・Vプーリー・Vベルト・基礎ボルト

BH Type (Dry vacuum type blower) (乾式真空用ブロワ)



Performance Chart 性能表 (1m³/min≒35.315CFM)

Model 型式	Bore 口径	min ⁻¹ 回転速度	Standard suction state air capacity (m ³ /min) and power requirements (kW) 標準吸込状態空気量 (m ³ /min) および所要動力 (kW)									
			-10kPa (-1020mmAq)		-20kPa (-2040mmAq)		-30kPa (-3060mmAq)		-40kPa (-4080mmAq)		-50kPa (-5100mmAq)	
			m ³ /min	kW	m ³ /min	kW	m ³ /min	kW	m ³ /min	kW	m ³ /min	kW
BH50	50A (2B)	1150	1.47	0.7	1.28	1.0	1.08	1.3	0.89	1.6		
		1250	1.65	0.7	1.46	1.0	1.26	1.4	1.07	1.7		
		1350	1.83	0.8	1.64	1.1	1.44	1.5	1.25	1.8		
		1400	1.92	0.8	1.73	1.2	1.53	1.6	1.34	1.9		
		1550	2.19	0.9	2.00	1.3	1.80	1.7	1.61	2.1		
		1700	2.46	1.0	2.27	1.4	2.07	1.9	1.88	2.3		
BH65	65A (2 1/2 B)	1150	2.01	0.7	1.69	1.2	1.41	1.6	1.17	2.1		
		1250	2.26	0.8	1.94	1.3	1.66	1.8	1.42	2.3		
		1400	2.64	0.9	2.32	1.4	2.04	2.0	1.80	2.6		
		1550	3.01	1.0	2.69	1.6	2.41	2.2	2.17	2.8		
		1700	3.39	1.1	3.07	1.7	2.79	2.4	2.55	3.1		
BH80	80A (3B)	1150	3.40	1.2	3.02	1.8	2.72	2.5	2.47	3.2	2.27	3.9
		1250	3.76	1.3	3.38	2.0	3.08	2.7	2.83	3.5	2.63	4.2
		1400	4.30	1.4	3.92	2.2	3.62	3.0	3.37	3.9	3.17	4.7
		1550	4.84	1.6	4.46	2.5	4.16	3.4	3.91	4.3	3.71	5.2
		1700	5.38	1.7	5.00	2.7	4.70	3.7	4.45	4.7	4.25	5.7
BH100	100A (4B)	1100	4.46	1.7	4.12	2.5	3.79	3.3	3.45	4.3	3.11	5.2
		1300	5.46	2.1	5.12	2.9	4.79	3.9	4.45	5.1	4.11	6.2
		1450	6.22	2.3	5.88	3.3	5.55	4.4	5.21	5.7	4.87	6.9
		1550	6.72	2.5	6.38	3.5	6.05	4.7	5.71	6.0	5.37	7.4
		1750	7.72	2.8	7.38	3.9	7.05	5.3	6.71	6.8	6.37	8.3
		1950	8.72	3.1	8.38	4.4	8.05	5.9	7.71	7.6	7.37	9.3
BH125	125A (5B)	1100	6.95	2.3	6.55	3.5	6.15	4.9	5.75	6.3	5.35	7.8
		1300	8.49	2.7	8.09	4.1	7.69	5.7	7.29	7.5	6.89	9.3
		1450	9.65	3.0	9.25	4.6	8.85	6.4	8.45	8.3	8.05	10.3
		1550	10.4	3.2	10.0	4.9	9.60	6.8	9.20	8.9	8.80	11.0
		1750	12.0	3.6	11.6	5.6	11.2	7.7	10.8	10.1	10.4	12.5
		1950	13.5	4.0	13.1	6.2	12.7	8.6	12.3	11.2	11.9	13.9
BH125A	125A (5B)	1100	9.73	2.6	9.33	4.5	9.03	6.4	8.63	8.4	8.23	10.5
		1300	11.8	3.0	11.4	5.3	11.1	7.6	10.7	10.0	10.3	12.4
		1450	13.3	3.4	12.9	5.9	12.6	8.5	12.2	11.1	11.8	13.8
		1550	14.3	3.6	13.9	6.3	13.6	9.0	13.2	11.9	12.8	14.8
		1750	16.4	4.1	16.0	7.1	15.7	10.2	15.3	13.4	14.9	16.7
		1950	18.5	4.6	18.1	7.9	17.8	11.4	17.4	15.0	17.0	18.6

Outline Drawing 外形寸法図

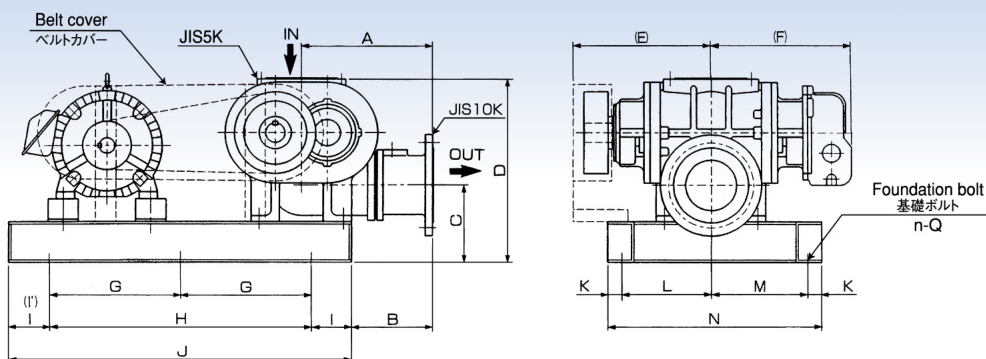

unit 単位 : mm

Model 型式	A	B	C	D	E	F	G	H	I	J	K	L	M	N	n	Q	Weight (kg) 質量
BH50	165	100	120	330	250	230	—	460	50	560	20	190	130	360	4	M12	70
BH65	165	100	129	348	270	265	—	460	50	560	20	210	110	360	4	M12	93
BH80	262	152	155	385	260	253	—	550	50	650	20	200	180	420	4	M12	115
BH100	277	167	180	415	320	288	—	600	50(100)	750	25	185	265	500	4	M12	120
BH125	327	202	190	455	365	350	—	650	100	850	35	220	240	530	4	M12	215
BH125A	327	202	190	455	415	400	—	650	100	850	35	270	260	600	4	M12	275

● Weight shown covers the blower with standard accessories without motor
● Standard accessories: Base・Belt cover・V-pulley・V-belt・Foundation bolt

● 質量はモータを除いた標準付属品付の値です。
● 標準付属品：ベース・ベルトカバー・Vプーリー・Vベルト・基礎ボルト

BH-T (Wet type vacuum type blower) (湿式真空用ブロワ) Type



● Performance Chart 性能表 (1m³/min≒35.315CFM)

Model 型式	Bore 口径	min ⁻¹ 回転速度	Standard suction state air capacity (m ³ /min) and power requirements (kW) 標準吸込状態空気量 (m ³ /min) および所要動力 (kW)												The amount of sealing water 封水量 l/min
			-20kPa (-2040mmAq)		-30kPa (-3060mmAq)		-40kPa (-4080mmAq)		-50kPa (-5100mmAq)		-60kPa (-6120mmAq)		-70kPa (-7140mmAq)		
			m ³ /min	kW	m ³ /min	kW	m ³ /min	kW	m ³ /min	kW	m ³ /min	kW	m ³ /min	kW	
BH80T	80A (3B)	1150	3.34	2.0	3.20	2.6	2.96	3.4	2.67	4.1	2.23	4.8	1.61	5.5	5
		1250	3.70	2.1	3.56	2.9	3.32	3.7	3.03	4.4	2.59	5.2	1.97	6.0	
		1400	4.24	2.4	4.10	3.2	3.86	4.1	3.57	4.9	3.13	5.8	2.51	6.7	
		1550	4.78	2.6	4.64	3.6	4.40	4.6	4.11	5.5	3.67	6.5	3.05	7.4	
		1700	5.32	2.9	5.18	3.9	4.94	5.0	4.65	6.0	4.21	7.1	3.59	8.1	
BH100T	100A (4B)	1300	5.37	3.1	5.16	4.3	4.84	5.3	4.45	6.5	3.67	7.6	2.70	8.7	6
		1450	6.12	3.5	5.91	4.8	5.59	5.9	5.20	7.2	4.42	8.5	3.45	9.7	
		1550	6.63	3.7	6.42	5.1	6.10	6.4	5.71	7.7	4.93	9.1	3.96	10.3	
		1750	7.63	4.2	7.42	5.7	7.10	7.2	6.71	8.7	5.93	10.2	4.96	11.7	
		1950	8.63	4.7	8.42	6.4	8.10	8.0	7.71	9.7	6.93	11.4	5.96	13.0	
BH125T	125A (5B)	1300	8.5	4.3	8.2	6.1	7.8	7.9	7.3	9.6	6.4	11.3	5.1	13.1	8
		1450	9.6	4.8	9.3	6.8	8.9	8.8	8.4	10.7	7.5	12.6	6.2	14.6	
		1550	10.4	5.2	10.1	7.2	9.7	9.4	9.2	11.4	8.3	13.5	7.0	15.7	
		1750	12.0	5.8	11.7	8.2	11.3	10.6	10.8	12.9	9.9	15.3	8.6	17.7	
		1950	13.5	6.5	13.2	9.1	12.8	11.8	12.3	14.4	11.4	17.0	10.1	19.7	
BH125AT	125A (5B)	1300	11.9	5.6	11.6	8.0	11.2	10.5	10.6	12.9	9.70	15.5	8.00	18.0	8
		1450	13.4	6.2	13.1	8.9	12.7	11.7	12.1	14.4	11.2	17.2	9.50	20.1	
		1550	14.4	6.6	14.1	9.6	13.7	12.5	13.1	15.4	12.2	18.4	10.5	21.4	
		1750	16.5	7.5	16.2	10.8	15.8	14.1	15.2	17.4	14.3	20.8	12.6	24.2	
		1950	18.6	8.4	18.3	12.0	17.9	15.7	17.3	19.4	16.4	23.2	14.7	27.0	
BH150T	150A (6B)	1050	18.1	8.1	17.8	11.4	17.3	14.7	16.6	18.0	15.5	21.3	13.8	24.7	10
		1150	19.9	8.8	19.6	12.5	19.1	16.1	18.4	19.7	17.3	23.4	15.6	27.0	
		1250	21.8	9.6	21.5	13.5	21.0	17.5	20.3	21.5	19.2	25.4	17.5	29.4	
		1400	24.5	10.7	24.2	15.2	23.7	19.6	23.0	24.0	21.9	28.5	20.2	32.9	
		1550	27.3	11.9	27.0	16.8	26.5	21.7	25.8	26.6	24.7	31.5	23.0	36.4	

● Outline Drawing 外形寸法図

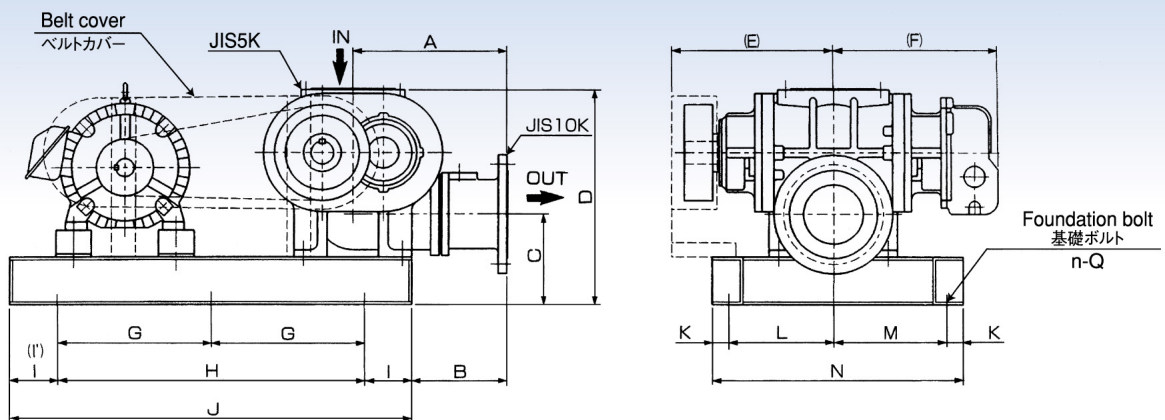

unit 単位 : mm

Model 型式	A	B	C	D	E	F	G	H	I (I')	J	K	L	M	N	n	Q	Weight (kg) 質量
BH80T	262	152	155	385	260	253	—	550	50	650	20	200	180	420	4	M12	115
BH100T	277	167	180	415	320	288	—	600	50 (100)	750	25	185	265	500	4	M12	120
BH125T	327	202	190	455	365	350	—	650	100	850	35	220	240	530	4	M12	215
BH125AT	327	202	190	455	415	400	—	650	100	850	35	270	260	600	4	M12	275
BH150T	412	252	235	595	430	410	—	800	100	1000	35	270	260	600	4	M12	355

- Weight shown covers the blower with standard accessories without motor
- Standard accessories: Base・Belt cover・V-pulley・V-belt・Foundation bolt
- 質量はモータを除いた標準付属品付の値です。
- 標準付属品：ベース・ベルトカバー・Vプーリー・Vベルト・基礎ボルト

Special Accessories

特別付属品

* Specially attached connecting flange is equivalent to JIS10K.
 ※特別付属品の接続フランジはJIS10K相当です。

Delivery silencer ADS 吐出サイレンサ ADS

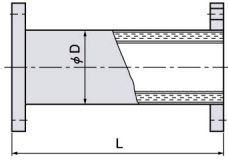

unit 単位 : mm

Model 型式	D	L	Weight 質量 (kg)
ADS20A	43	525	4.0
ADS25A	43	525	4.5
ADS32A	49	525	5.3
ADS40A	61	580	6.5
ADS50A	76	815	9.1
ADS65A	76	785	11.7
ADS80A	89	900	12.6
ADS100A	114	900	17.8
ADS125A	140	1000	27.8
ADS150A	165	1000	31.2
ADS200A	216	1000	42.5
ADS250A	267	1000	72.0
ADS300A	319	1000	88.0

Delivery silencer AGOS 吐出サイレンサ AGOS

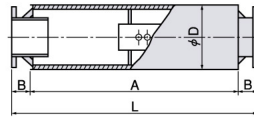

unit 単位 : mm

Model 型式	A	B	D	L	Weight 質量 (kg)
AGOS25A	286	64	114	414	5.7
AGOS32A	412	60	140	532	8.8
AGOS40A	460	60	165	580	10
AGOS50A	695	60	216	815	19
AGOS65A	665	60	216	785	18
AGOS80A	770	65	216	900	22
AGOS100A	860	70	216	1000	26
AGOS125A	1040	110	267	1260	42
AGOS150A	1200	90	319	1380	56
AGOS200A	1600	90	356	1780	94
AGOS250A	1600	100	406	1800	124
AGOS300A	1800	100	457	2000	155
AGOS350A	1800	100	508	2000	195
AGOS400A	2000	150	559	2300	280

Delivery silencer ASNS 吐出サイレンサ ASNS

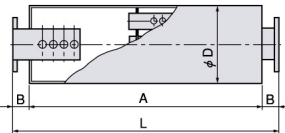

unit 単位 : mm

Model 型式	A	B	D	L	Weight 質量 (kg)
ASNS40A	460	60	219	580	18
ASNS50A	695	60	219	815	21
ASNS65A	665	60	219	785	25
ASNS80A	770	65	219	900	29
ASNS100A	860	70	270	1000	39
ASNS125A	1090	85	321	1260	50
ASNS150A	1210	85	409	1380	98
ASNS200A	1600	90	460	1780	125
ASNS250A	1600	100	511	1800	178
ASNS300A	1800	100	613	2000	290
ASNS350A	1800	100	714	2000	380
ASNS400A	2000	150	816	2300	500

Delivery silencer AGL-V 放出サイレンサ AGL-V

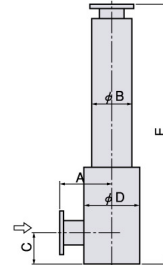

unit 単位 : mm

Model 型式	A	B	C	D	E	Weight 質量 (kg)
AGL40VA	150	114	100	140	770	18
AGL50VA	170	140	100	165	820	20
AGL65VA	190	165	120	216	1000	27
AGL80VA	210	165	140	216	1150	31
AGL100VA	250	202	170	319	1390	47
AGL125VA	300	255	180	406	1700	60
AGL150VA	330	319	200	457	1800	83

Check valve AC-F チャッキ弁 AC-F

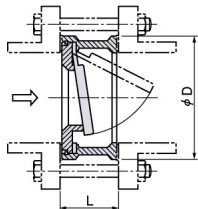

unit 単位 : mm

Model 型式	D	L	Weight 質量 (kg)
AC32F	81	43	0.8
AC40F	86	43	0.9
AC50F	101	43	1.2
AC65F	121	50	1.8
AC80F	131	60	2.3
AC100F	156	70	3.5
AC125F	187	100	5.8
AC150F	217	140	9.0
AC200F	267	180	16
AC250F	330	220	20
AC300F	375	260	25

Swing check valve ACN ねじ込み式チャッキ弁 ACN

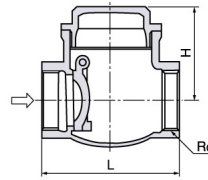

unit 単位 : mm

Model 型式	Rc	H	L	Weight 質量 (kg)
ACN20	3/4	45	70	0.4
ACN25	1	52	80	0.6
ACN32	1 1/4	62	92	0.9
ACN40	1 1/2	67	102	1.2
ACN50	2	79	122	2.0

Flexible joint (rubber) AFD-N フレキシブルジョイント(ゴム製) AFD-N

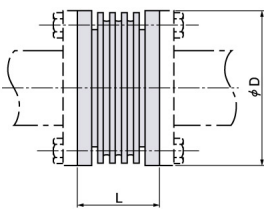

unit 単位 : mm

Model 型式	D	L	Weight 質量 (kg)
AFD25N	125	100	1.5
AFD32N	135	100	1.6
AFD40N	140	100	1.7
AFD50N	155	100	2.1
AFD65N	175	100	2.4
AFD80N	185	100	2.8
AFD100N	210	100	3.3
AFD125N	250	100	4.5
AFD150N	280	100	10.7
AFD200N	330	150	15.2

Flexible joint (stainless steel) AFR フレキシブルジョイント(ステンレス製) AFR

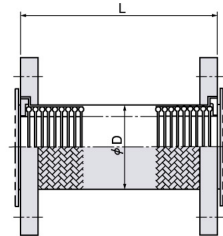

unit 単位 : mm

Model 型式	D	L	Weight 質量 (kg)
AFR20	36	200	2.5
AFR25	45	200	2.5
AFR32	54	200	3.3
AFR40	60	200	3.5
AFR50	70	200	4.2
AFR65	84	230	5.9
AFR80	95	230	5.9
AFR100	121	230	7.1
AFR125	148	300	11
AFR150	172	300	15
AFR200	235	300	19
AFR250	285	350	32
AFR300	336	350	35

Flexible joint ATF ねじ込み式フレキシブルジョイント ATF

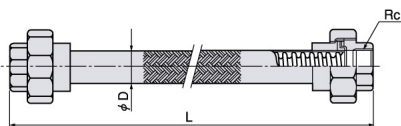

unit 単位 : mm

Model 型式	Rc	D	L	Weight 質量 (kg)
ATF20	3/4	26.9	200	0.6
ATF25	1	34.0	200	0.9
ATF32	1 1/4	42.2	300	1.3
ATF40	1 1/2	48.6	300	1.7
ATF50	2	63.1	300	2.4

Inlet frange VTA 真空安全弁短管 VTA

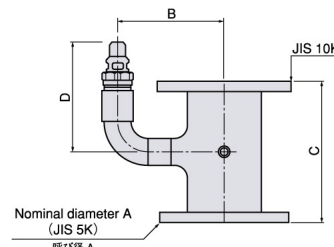

unit 単位 : mm

Model 型式	A	B	C	D
VTA501A	50	135	139	159
VTA502A	50	140	139	184
VTA651A	65	145	165	159
VTA652A	65	150	165	184
VTA802A	80	153	184	184
VTA804A	80	153	184	247
VTA1002A	100	165	222	184
VTA1004A	100	165	222	247
VTA1254A	125	181	266	247
VTA1256A	125	225	266	334
VTA1504A	150	197	304	247
VTA1506A	150	238	304	334
VTA2006A	200	267	375	334
VTA2007A	200	308	375	420
VTA2507A	250	337	450	420

Example of usage at vacuum model

真空仕様用途例

Food Processing 食品加工機

Vacuum 真空
Chicken pieces 鳥肉
Basket かご
Roots-type vacuum pump ルーツ式真空ポンプ

Vacuum conditions are useful in the seasoning of foods.
真空を利用して食品の味付けに使用されています。

Vacuum Drying for Hydrocarbon Solvent Washing Machines 炭化水素系洗浄機用真空乾燥

Washing tank 洗浄タンク
Drying tank 乾燥タンク
Condenser コンデンサ
Roots-type vacuum pump ルーツ式真空ポンプ
Reuse 再利用

Here, a Roots-type vacuum pump that can collect solvent drainage is ideal (used with drainage pot).
溶剤のドレン回収ができるルーツ式真空ポンプが最適です。(ドレンポット付)

Vacuum Drying for Water-based Washing Machines 水系洗浄機用真空乾燥

Solution insertion mouth 液仕込口
Evaporator 蒸発器
Condenser コンデンサ
Roots-type vacuum pump ルーツ式真空ポンプ
Drain ドレン
Concentrated solution 濃縮液

Used to vacuum dry the moisture.
水分の真空乾燥に利用されています。

Leak Tester リークテスター

Gasket ガスケット
Roots-type vacuum pump ルーツ式真空ポンプ

Can be used in tests of airtightness.
気密テストに使用できます。

Vacuum Packing of Food 食料品真空パック

Roots-type vacuum pump ルーツ式真空ポンプ
Pack パック

Vacuum packing keeps foods such as meat and vegetables fresh.
野菜・肉等生鮮食料品のパック詰りに利用されています。

Freeze Drying 凍結乾燥

Roots-type vacuum pump ルーツ式真空ポンプ
Tank タンク

Freshness and quality of vegetables and other foods can also be preserved by freezing the foods in tanks under vacuum conditions.
タンク内で、真空状態により食品を凍らせることで、野菜やその他の食品の鮮度と品質を保つことができます。

Adsorption Conveyance 吸着搬送機

Roots-type vacuum pump ルーツ式真空ポンプ

Adsorption conveyance by vacuum pump is well suited to heavy materials such as steel plates and easily breakable materials such as glass. Energy savings are promoted by the elimination of gripping operations.
鉄板等の重量物やガラス等の破損しやすいもの等の吸着搬送ができます。締付作業がなく省力化につながります。

Particle Transport 粉粒体輸送

Filter フィルタ
Tank タンク
Roots-type vacuum pump ルーツ式真空ポンプ
Secondary air 二次空気
Particles 粉粒体

Used in the conveyance of rice, wheat, soybeans, resin pellets, etc.
米、麦、大豆、樹脂ペレット等の輸送に使用されています。

Combustion Gas Recovery 燃焼ガス回収

Boiler ボイラ
Filter フィルタ
Roots-type vacuum pump ルーツ式真空ポンプ
Roots blower ルーツブロワ

Also used in the desulfurization of high-temperature combustion gas and flue gas.
高温度の燃焼ガス・排煙脱硫にも利用されています。

Vacuum Molding 真空成型

Plastic sheet プラスチックシート
Roots-type vacuum pump ルーツ式真空ポンプ
Trap トラップ

Roots-type vacuum pumps are used as vacuum sources for vacuum molders used with resins, etc. (trap attached).
樹脂等の真空成形機の真空源に使用されています。(トラップ付)

Vacuum Defoaming 真空脱泡

Roots-type vacuum pump ルーツ式真空ポンプ
Air bubbles 気泡
Trap トラップ
Tank タンク

Product quality is improved for chemicals and pharmaceuticals by using a Roots-type vacuum pump to remove air bubbles by defoaming under vacuum.
化学・薬品等の製造工程で生じた気泡をなくすために、真空下で脱泡をすることで製品の品質が高まります。

Impregnation 含浸

Compressor コンプレッサ
Roots-type vacuum pump ルーツ式真空ポンプ
Tank タンク

In this setup, our pumps first produce a vacuum in the tank and then supply high pressure to facilitate the impregnation of parts with liquids or gases.
液体やガス等を部品に含浸しやすくするためにタンク内を真空にし、その後高圧を供給します。

FT2 (Air cooled type) (空冷式) Type

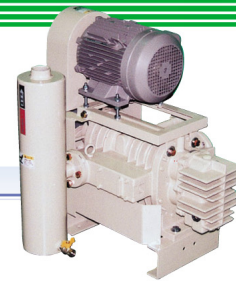

● Performance Chart 性能表

Specification 仕様	Model 型式	FT2-20	FT2-45	FT2-80	FT2-150
Suction bore 吸込口径 (A)		15	25	32	50
Discharge bore 吐出口径 (A)		15	25	25	40
Designed exhaust speed 設計排気速度 (m ³ /min)		0.34	0.82	1.27	2.38
Motor output モーター出力 (kW)		0.75×2P	1.5×2P	2.2×2P	3.7×4P
Rotation speed 回転速度 (min ⁻¹)		2700	3000	3000	1700
Ultimate pressure 到達圧力 (kPa)		8 {60Torr}	5.3 {40Torr}	5.3 {40Torr}	4 {30Torr}
Noise dB (A) 8kPa {60Torr} at 1m 騒音 dB (A) 8kPa {60Torr}		72	74	78	80

● Performance curve 性能曲線

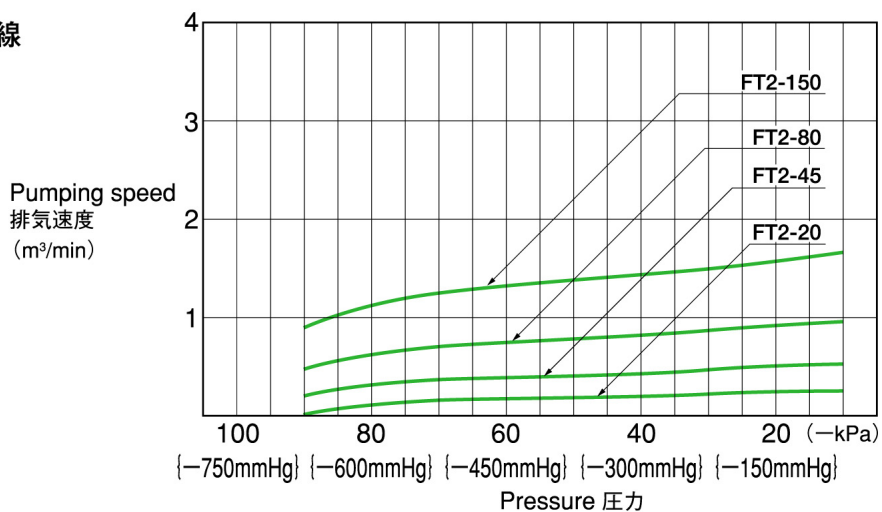

● Outline Drawing 外形寸法図

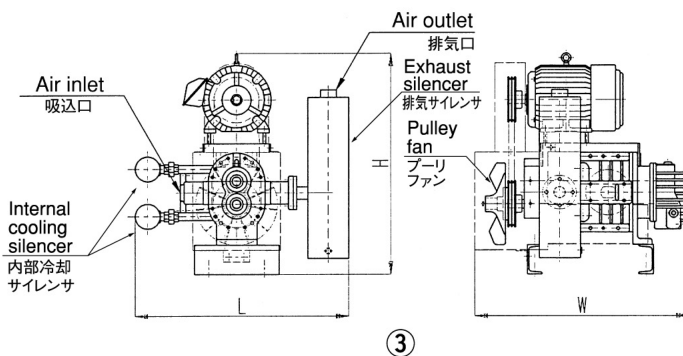
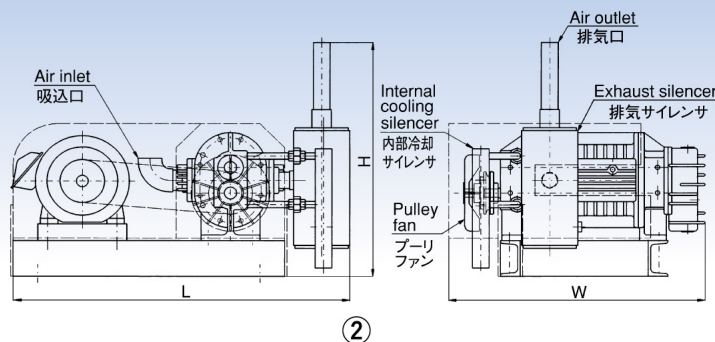
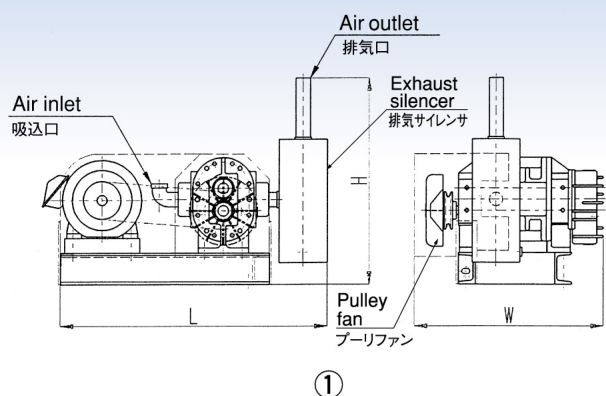

unit 単位 : mm

Model 型式	L	W	H	Weight (kg) 質量	No.
FT2-20	565	365	380	38	①
FT2-45	630	455	490	59	①
FT2-80	680	520	490	72	②
FT2-150	730	730	755	155	③

- Weight shown covers the vacuum pump with standard accessories without motor.
- Standard accessories: Base·Belt cover·Pulley fan·V-pulley·V-belt·Exhaust silencer·Internal cooling silencer (FT2-80·150)·Foundation bolt
- 質量は標準付属品とモーター付きの概略値です。
- 標準付属品：ベース、ベルトカバー、プーリファン、Vベルト、排気サイレンサ、内部冷却サイレンサ、基礎ボルト

FT3 (Compact vacuum pump) (小型真空ポンプ) Type



Performance Chart 性能表

Specification 仕様	Model 型式	FT3-25		FT3-40		FT3-50	
Suction bore 吸込口径 (A)		20		20		20	
Discharge bore 吐出口径 (A)		10		15		15	
Designed exhaust speed 設計排気速度 (m ³ /min)		0.36	0.43	0.52	0.62	0.77	0.93
Motor output モータ出力 (kW)		0.75		1.5		1.5	
Rotation speed 回転速度 (min ⁻¹)		3000/50Hz	3600/60Hz	3000/50Hz	3600/60Hz	3000/50Hz	3600/60Hz
Noise dB (A) 1.3kPa {10Torr} at 1m 騒音 dB (A) 1.3kPa [10Torr]		74	76	75	78	76	79

Performance curve 性能曲線

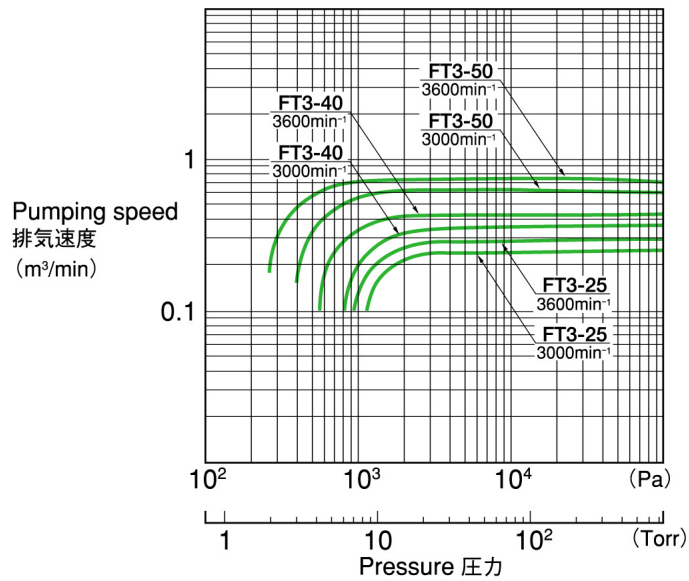

Outline Drawing 外形寸法図

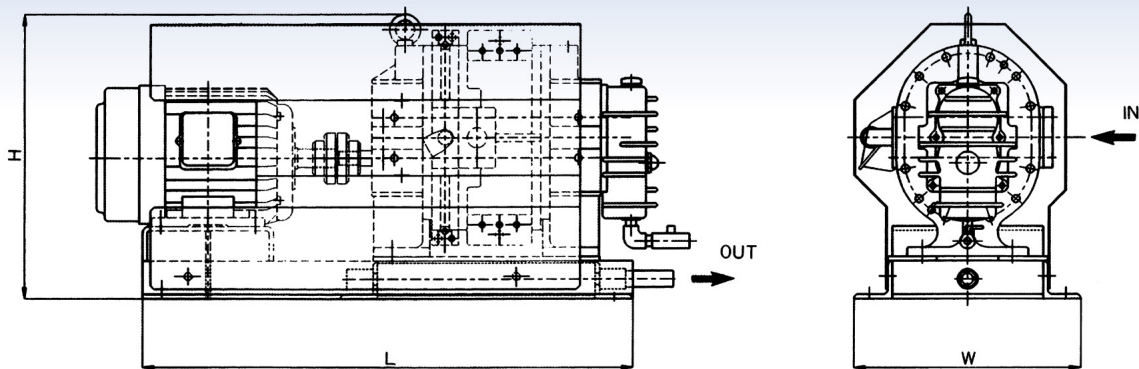

unit 単位 : mm

Model 型式	L	W	H	Weight (kg) 質量
FT3-25	575	300	380	90
FT3-40	650	300	380	110
FT3-50	650	300	380	120

- Weight shown covers the vacuum pump with standard accessories without motor.
- Standard accessories: Motor (Totally-enclosed fan-cooled type) · Base · Wind guide · Coupling
- 質量は標準付属品とモータ付きの概略値です。
- 標準付属品：モータ(全閉外扇型)、ベース、風ガイド、カップリング

FT3-L (Air cooled type) (空冷式) Type



Performance Chart 性能表

Specification 仕様	Model 型式	FT3-60L	FT3-100L	FT3-200L	FT3-350L	FT3-700L	FT3-1000L
Suction bore 吸込口径 (A)		40	40	50	65	80	100
Discharge bore 吐出口径 (A)		25	25	32	50	65	65
Designed exhaust speed 設計排気速度 (m ³ /min)		1.26	2.08	3.82	5.13	6.41	11.3
Motor output モータ出力 (kW)		2.2	3.7	5.5	7.5	11	18.5
Rotation speed 回転速度 (min ⁻¹)		1800	2300	2000	1600	2000	1750
Cooling fan output 冷却ファン出力 (W)		50	150	200	750	750	750
Noise dB (A) 8kPa {60Torr} at 1m 騒音 dB (A) 8kPa {60Torr}		75	76	78	81	83	85

Performance curve 性能曲線

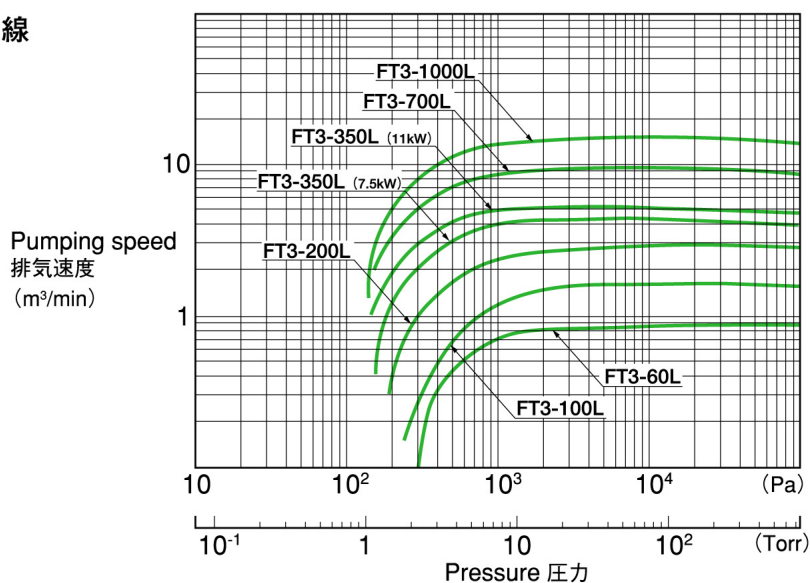

Outline Drawing 外形寸法図

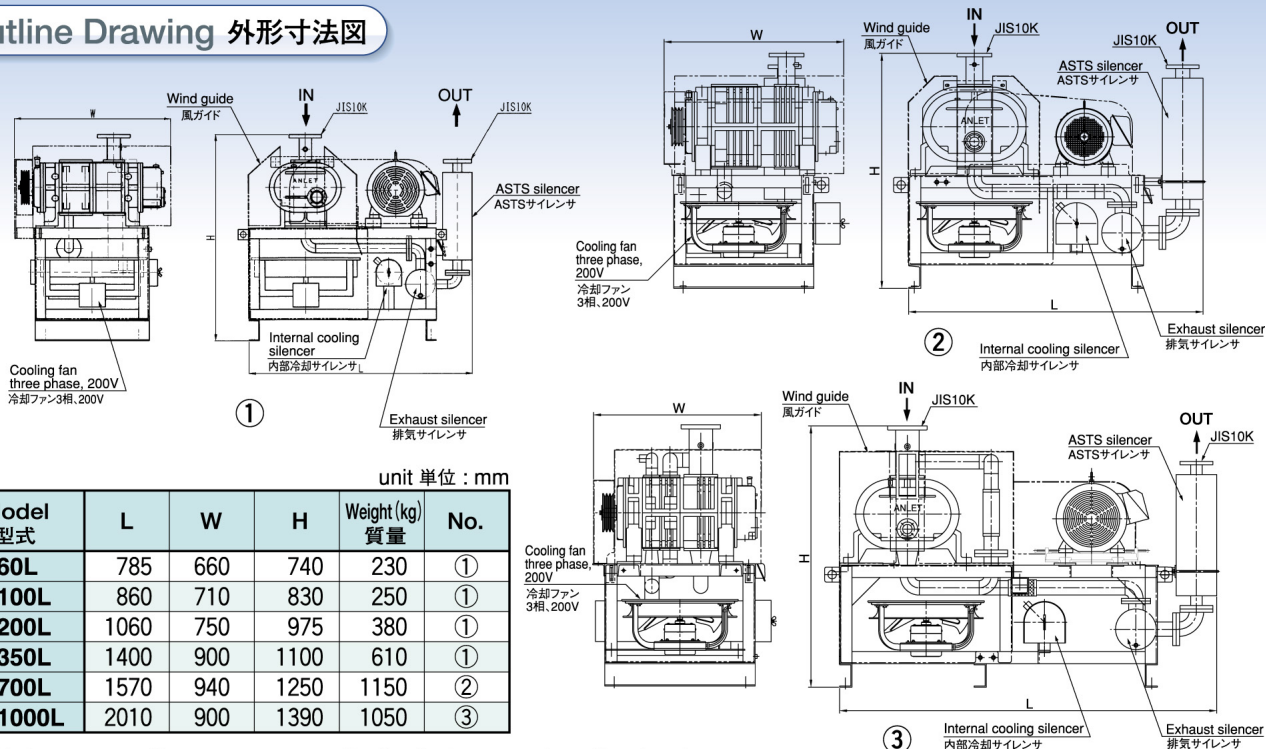

unit 単位 : mm

Model 型式	L	W	H	Weight (kg) 質量	No.
FT3-60L	785	660	740	230	①
FT3-100L	860	710	830	250	①
FT3-200L	1060	750	975	380	①
FT3-350L	1400	900	1100	610	①
FT3-700L	1570	940	1250	1150	②
FT3-1000L	2010	900	1390	1050	③

- Weight shown covers the vacuum pump with standard accessories without motor.
- Standard accessories: Base · Belt cover · V-pulley · V-belt · Exhaust silencer · Cooling fan · Wind guide · Internal cooling silencer · ASTS silencer · Silencer support (FT3-700L~FT3-1000L) · Foundation bolt
- 質量は標準付属品とモータ付きの概略値です。
- 標準付属品：ベース、ベルトカバー、Vプーリー、Vベルト、排気サイレンサ、冷却ファン、風ガイド、内部冷却サイレンサ、ASTSサイレンサ、サイレンササポート (FT3-700L~FT3-1000L)、基礎ボルト

FT4-LE (Air cooled type) (空冷式) Type



Performance Chart 性能表

Specification 仕様	Model 型式	FT4-50LE	FT4-65LE	FT4-150LE	FT4-200LE	FT4-300LE	FT4-450LE
Suction bore 吸込口径 (A)		25	25	50	50	80	80
Discharge bore 吐出口径 (A)		25	25	40	40	50	50
Designed exhaust speed 設計排気速度 (m ³ /min)		0.77	0.91	2.38	3.22	5.23	7.21
Motor output モータ出力 (kW)		1.5	2.2	3.7	5.5	7.5	11
Rotation speed 回転速度 (min ⁻¹)		2800	3300	1700	2300	1450	2000
Noise dB (A) 133Pa {1Torr} at 1m 騒音 dB (A) 133Pa [1Torr]		75	78	78	82	84	86

Performance curve 性能曲線

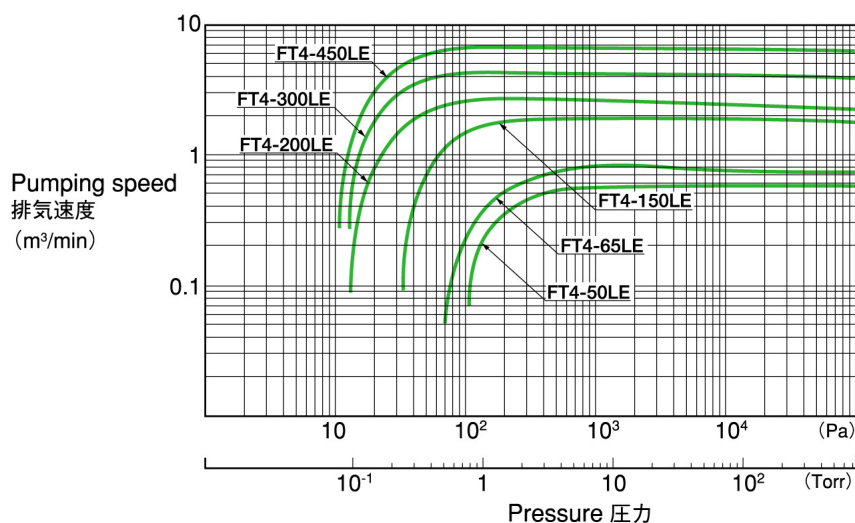

Outline Drawing 外形寸法図

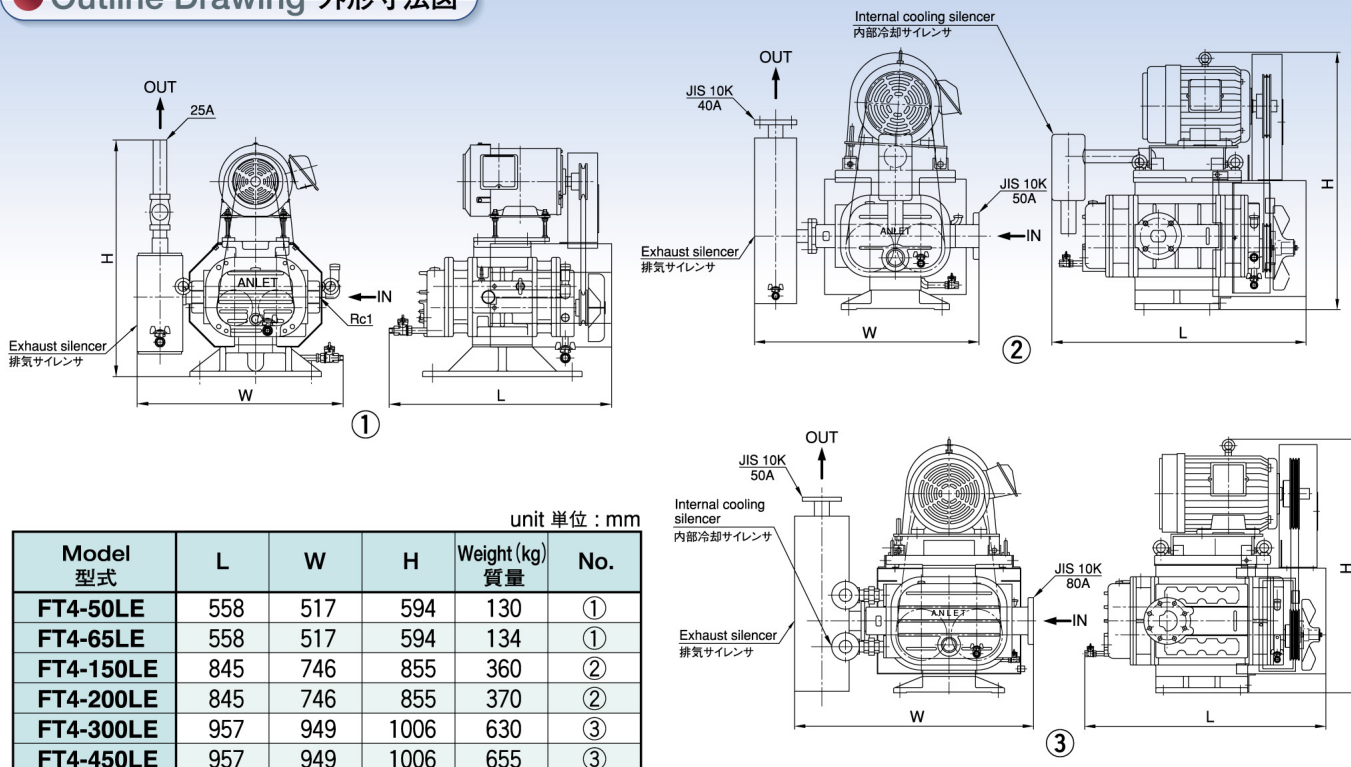

- Weight shown covers the vacuum pump with standard accessories without motor
- Standard accessories:
Fan cover · Pulley fan · V-pulley · V-belt · Exhaust silencer · Internal cooling silencer (Over FT4-150LE) · Foundation bolt
- 質量は標準付属品とモータ付きの概略値です。
- 標準付属品：ファンカバー、プーリファン、Vプーリ、Vベルト、排気サイレンサ、内部冷却サイレンサ (FT4-150LE以上)、基礎ボルト

CT4-LE (Water cooled model) (水冷式) Type



Performance Chart 性能表

Specification 仕様	Model 型式	CT4-50LE	CT4-65LE	CT4-150LE	CT4-200LE	CT4-300LE	CT4-450LE	CT4-700L
Suction bore 吸込口径 (A)		25	25	50	50	80	80	80
Discharge bore 吐出口径 (A)		25	25	40	40	50	50	65
Designed exhaust speed 設計排気速度 (m ³ /min)		0.77	1.00	2.38	3.22	5.23	7.21	11.5
Motor output モータ出力 (kW)		1.5	2.2	3.7	5.5	7.5	11	15
Rotation speed 回転速度 (min ⁻¹)		2800	3600	1700	2300	1450	2000	2000
Cooling water 冷却水量 (l/min)		2	2	7	7	15	15	15
Noise dB (A) 133Pa [1Torr] at 1m 騒音 dB (A) 133Pa [1Torr]		73	74	77	79	83	85	85

* Higher vacuum and displacement are achieved in combination with mechanical booster (ST1 Model).

※CT4-50LE・65LEのモータは3相・200V・2P。CT4-150LE～450LE・700Lのモータは3相・200V・4P。
※メカニカルブースタ(ST1型)との組み合わせで、さらに高真空・大排気量も可能です。

Performance curve 性能曲線

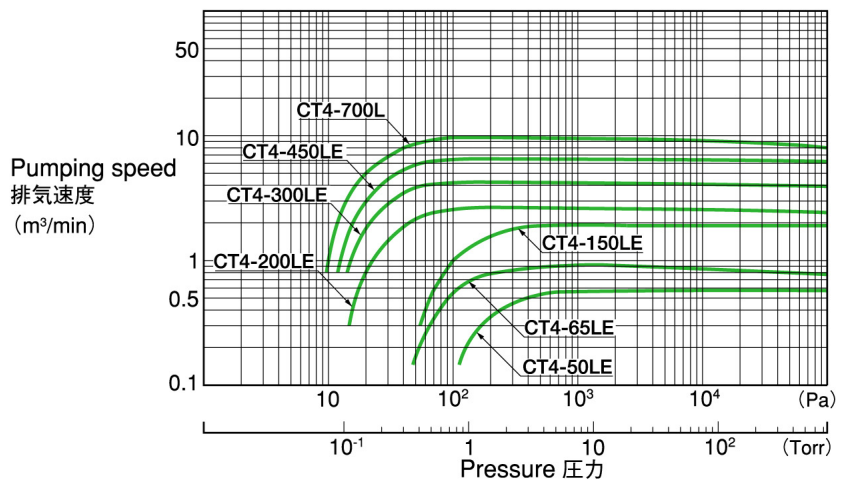

Outline Drawing 外形寸法図

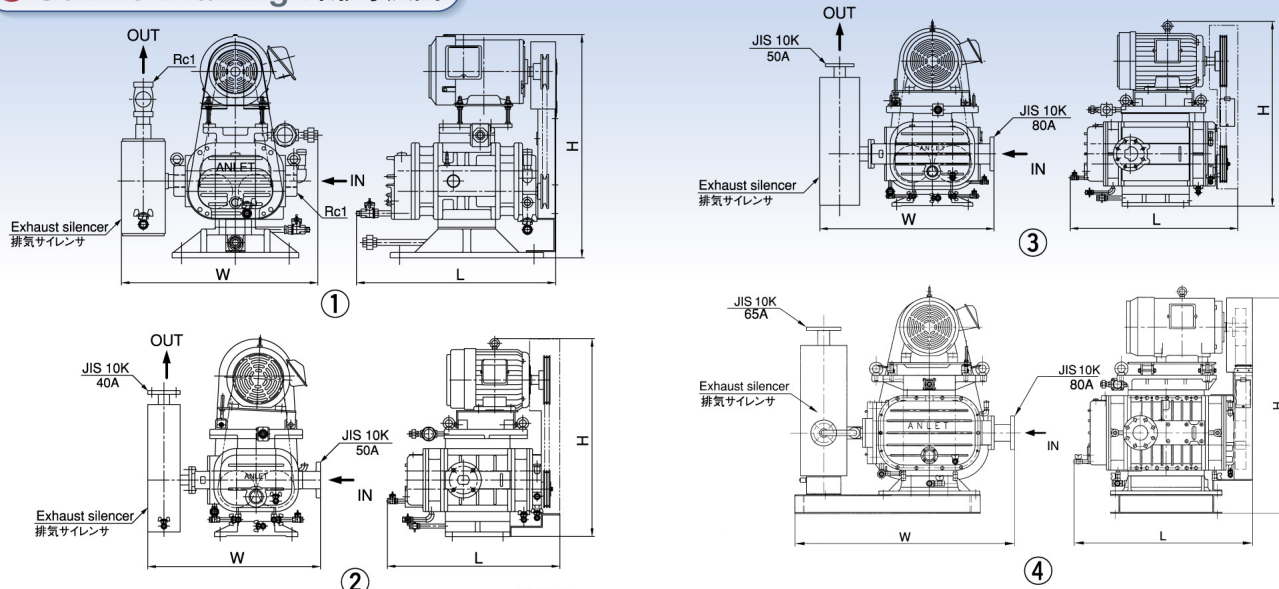

unit 単位 : mm

Model 型式	L	W	H	Weight (kg) 質量	No.
CT4-50LE	520	513	583	130	①
CT4-65LE	520	513	583	134	①
CT4-150LE	745	746	855	360	②
CT4-200LE	745	746	855	370	②
CT4-300LE	912	949	1006	630	③
CT4-450LE	912	949	1006	655	③
CT4-700L	960	1185	1155	1100	④

Standard accessories:

Base, belt cover, V-pulley, V-belt, exhaust silencer (CT4-150/200 is equipped with after cooler.), internal cooler (for CT-4-300/450 only), cooling water piping, foundation bolts

※Characteristic curves and dimensional drawings can be also referenced at our home page (<http://www.anlet.co.jp>). Please visit our site.

★Please check the cooling water quality avboid trouble.

標準付属品:

ベース、ベルトカバー、Vプーリ、Vベルト、排気サイレンサ、内部冷却サイレンサ、冷却水配管、基礎ボルト

※弊社ホームページ (<http://www.anlet.co.jp>) から特性曲線・外形寸法図が参照できますので利用して下さい。

● Weight is approximate value including standard auxiliary parts.

● 質量は標準付属品とモータ付きの概略値です。

CT3 (Water cooled model) (水冷式) Type



Performance Chart 性能表

Specification		Model	CT3-60U	CT3-100U	CT3-200U	CT3-350U		CT3-700	CT3-1000
Suction bore	吸込口径	(A)	40	40	50	65		80	100
Discharge bore	吐出口径	(A)	25	32	40	50		65	65
Designed exhaust speed	設計排気速度	(m ³ /min)	1.26	2.08	3.82	5.13	6.41	11.3	16.1
Motor output	モータ出力	(kW)	2.2	3.7	5.5	7.5	11	15	22
Rotation speed	回転速度	(min ⁻¹)	1800	2300	2000	1600	2000	1700	1700
Cooling water	冷却水量	(l/min)	7	7	10	12		15	20
Noise dB (A) 4kPa [30Torr] at 1m 騒音 dB (A) 4kPa [30Torr]			72	74	77	80	82	85	86

Performance curve 性能曲線

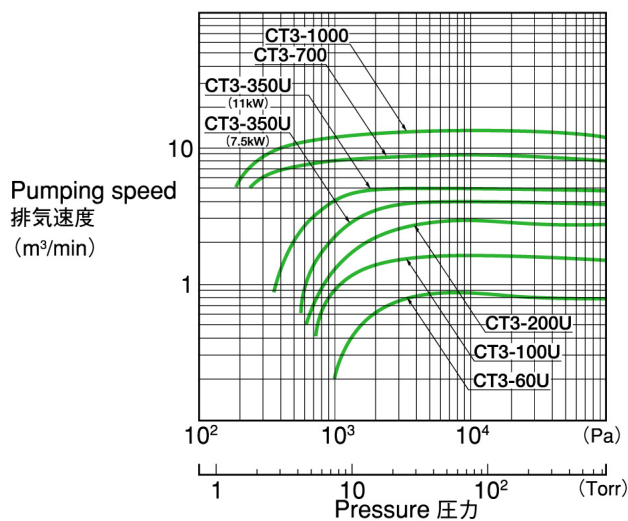

Outline Drawing 外形寸法図

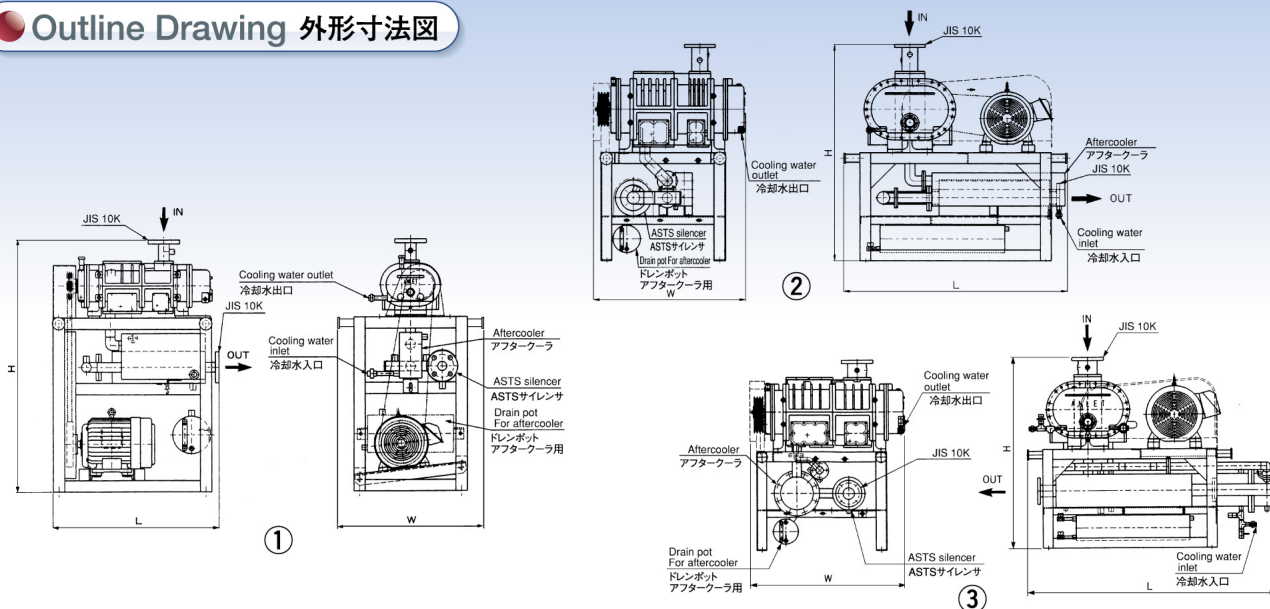

unit 単位 : mm

Model 型式	L	W	H	Weight (kg) 質量	No.
CT3-60U	686	610	1100	170	①
CT3-100U	733	660	1100	190	①
CT3-200U	796	700	1250	270	①
CT3-350U	1060	900	1450	470	①
CT3-700	1330	915	1300	1120	②
CT3-1000	1640	1025	1255	1460	③

● Weight is approximate value including standard auxiliary parts.
● 質量は標準付属品とモータ付きの概略値です。

- Standard accessories:
Base, belt cover, V-pulley, V-belt, exhaust silencer (ASTS), aftercooler, cooling water piping, drain pot for aftercooler, foundation bolts
- ※ Characteristic curves and dimensional drawings can be also referenced at our home page (<http://www.anlet.co.jp>). Please visit our site.
- ★ Please check the cooling water quality avboid trouble.
- 標準付属品:
ベース、ベルトカバー、Vプーリ、Vベルト、排気サイレンサ (ASTS)、アフタークーラ、冷却水配管、アフタークーラ用ドレンポット、基礎ボルト
- ※ 弊社ホームページ (<http://www.anlet.co.jp>) から特性曲線・外形寸法図が参照できますので利用して下さい。

Trap (pump protection device)

トラップ (真空ポンプの保護装置)

Used to capture fine particles, oil mist, etc. Excellent for dry vacuum pumps!!
 Capture efficiency is high, maintainability is good.

微粉じん、オイルミスト等の捕捉用としてドライ真空ポンプに最適!! 捕集効率が高く、メンテナンス性もよい。

Outline Drawing 外形寸法図

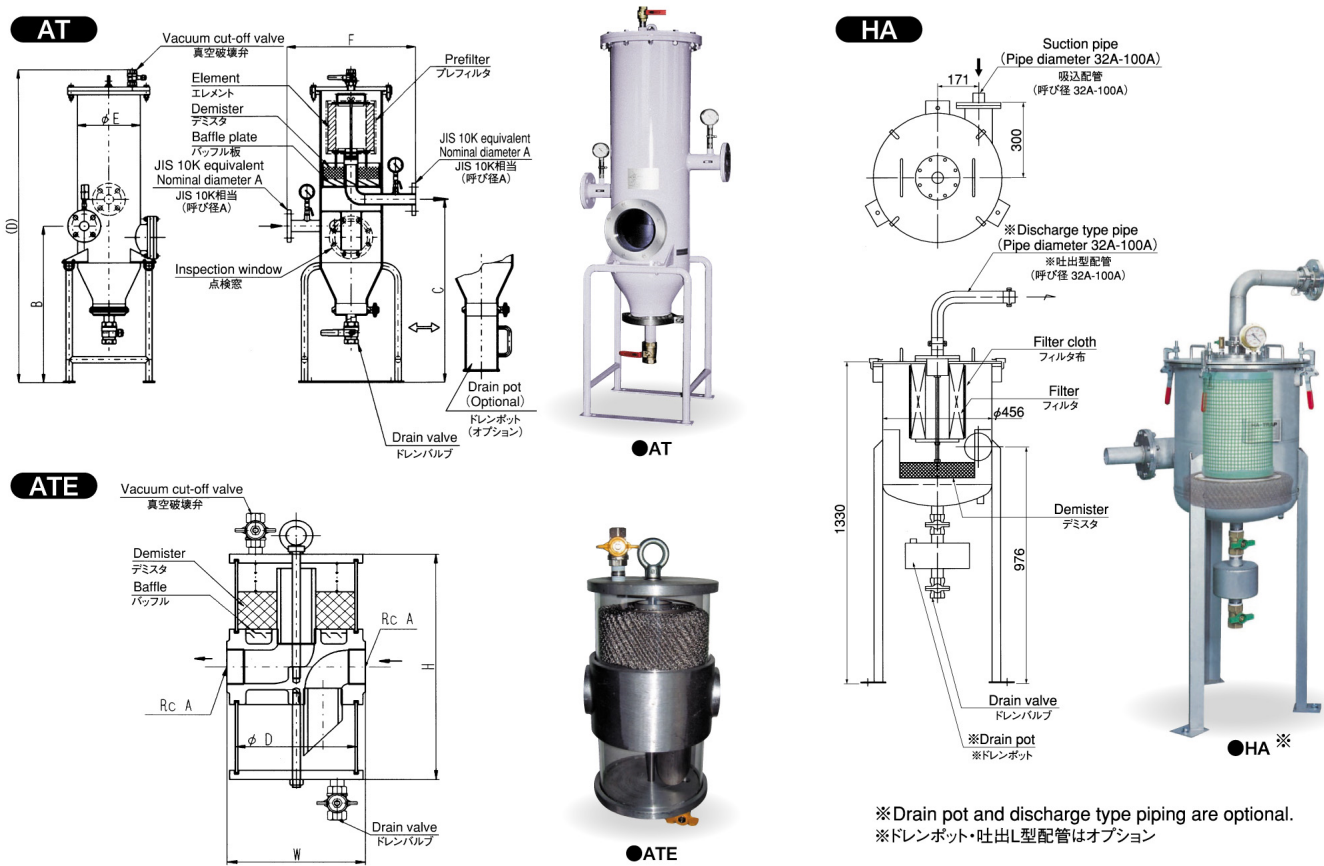

AT (Model) Dimension chart/corresponding model

AT (型) 寸法表・適応機種

unit 単位: mm

Model 型式	A	B	C	D	E	F	Weight (kg) 質量
AT 40A (D)	40	680	795	1360	267.4	550	79 (83)
AT 50A (D)	50	875	1000	1560	318.5	620	120 (124)
AT 65A (D)	65	875	1000	1560	318.5	620	121 (125)
AT 80A (D)	80	875	1000	1560	318.5	620	123 (127)
AT100A (D)	100	1010	1150	1800	457.2	750	220 (230)

*Figure inside () under weight column refer to weight when drain pot is attached.
 質量の () は「(D):ドレンポット付き」の値です。

Model 型式	Corresponding vacuum pump (rough standard) 適応真空ポンプ (目安)		
AT 40A (D)	FT3-60L	FT3-100L	CT3-60U
	CT3-100U		
AT 50A (D)	FT3-200L	CT3-200U	FT4-150LE
	FT4-200LE	CT4-150LE	CT4-200LE
AT 65A (D)	FT3-350L	CT3-350U	
AT 80A (D)	FT3-700L	CT3-700	FT4-300LE
	FT4-450LE	CT4-300LE	CT4-450LE
AT100A (D)	CT3-1000	FT3-1000L	

ATE (Model) Dimension chart/corresponding model

ATE 型寸法表・適応機種

unit 単位: mm

Model 型式	A	D	W	H	Weight (kg) 質量
ATE25	25	110	130	250	3.2
ATE40	40	150	170	300	6.0
ATE50	50	180	210	350	8.6
ATE80	80	250	290	520	20.7

Model 型式	Corresponding vacuum pump (rough standard) 適応真空ポンプ (目安)	
ATE25	CT4-50LE	CT4-65LE
	FT4-50LE	FT4-65LE
ATE40	CT3-60U	CT3-100U
	FT3-60L	FT3-100L
ATE50	CT3-200U	FT3-200L
	CT4-150LE	CT4-200LE
	FT4-150LE	FT4-200LE
ATE80	CT3-350U	FT3-350L
	CT4-300LE	CT4-450LE
	FT4-300LE	FT4-450LE

*Please ask the size of HA trap.
 *HAの寸法はお問い合わせ下さい。

Example of Blower piping

ブロウ配管例

Example of usage at discharging model

吐出仕様

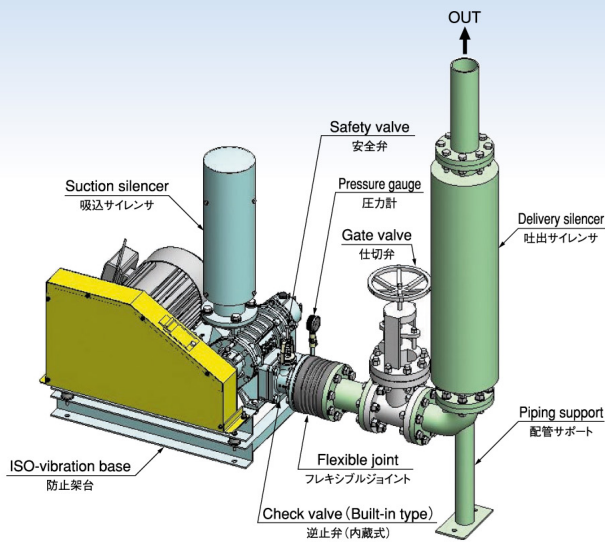

Example of usage at vacuum model (Dry type)

真空仕様 (乾式)

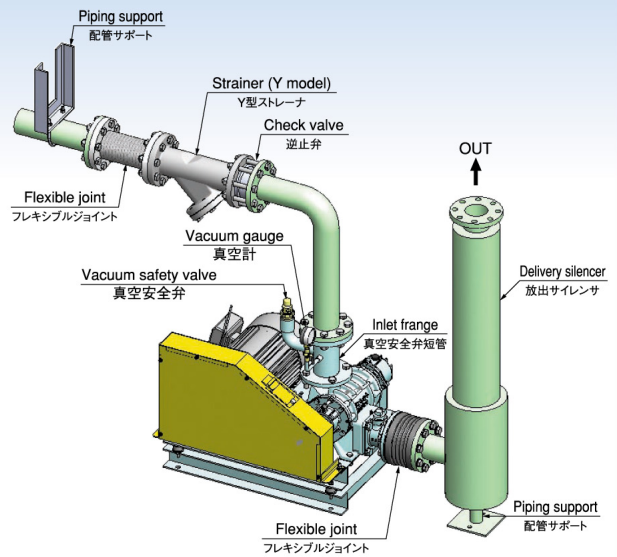

Example of usage at vacuum model (Wet type)

真空仕様 (湿式)

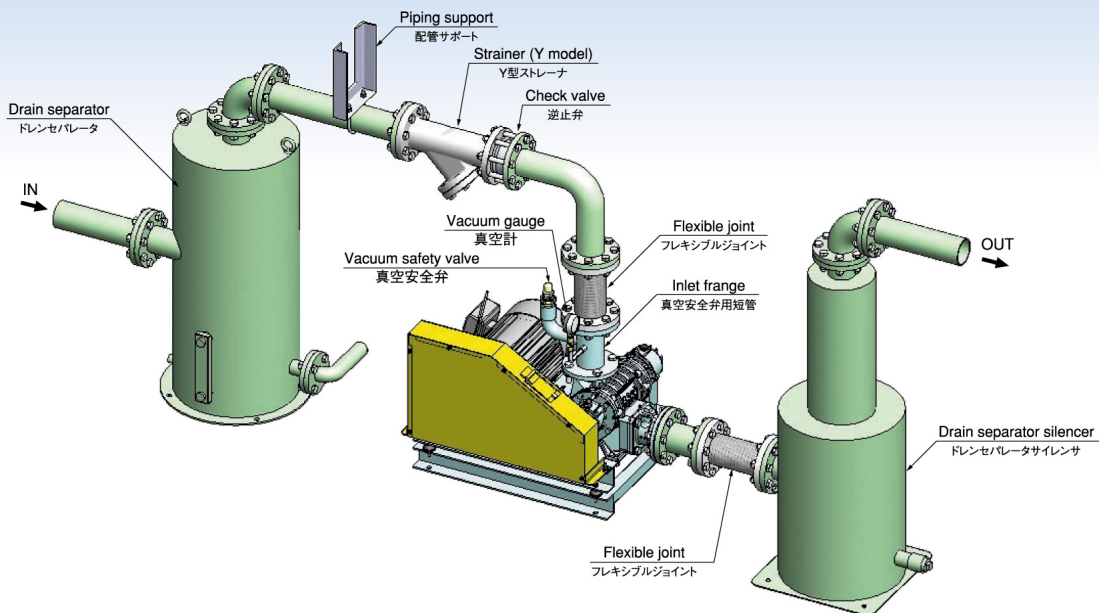

Caution 注意

- Please read the Instruction Manual carefully before using, and be sure to use your equipment properly. If you need a copy of the Instruction Manual, please contact our information office. We will send you one immediately.
- Please select a product that is well suited to your specific application and the environment of use. Use of a unit for the wrong application or in an inappropriate environment could result in an accident.
- We assume no liability to indemnify for secondary damage caused by accidents involving our products.
- ご使用の前に「取扱説明書」をよくお読みのうえ正しくお使いください。
「取扱説明書」が必要な方は弊社の窓口までご連絡ください。ただちにお送り致します。
- 使用環境及び用途に適した製品をお選びください。不適切な環境及び用途で使われますと事故の原因となります。
- 弊社は製品の故障に起因する二次的損害に関しては補償いたしません。

PH Type (Water pump) (水ポンプ)

Performance Chart 性能表

Model 型式	min ⁻¹ 回転速度	Discharge amount 吐出量		Discharge pump head 吐出揚程 (m)				
		L/min	Required power 所要動力	5m	10m	15m	20m	25m
PH 40	600	L/min	47	(10)	—	—	—	—
		kW	0.41	0.56	—	—	—	—
	700	L/min	70	30	—	—	—	—
		kW	0.50	0.72	—	—	—	—
	800	L/min	94	50	(13)	—	—	—
		kW	0.83	1.05	1.28	—	—	—
900	L/min	118	70	35	—	—	—	
	kW	1.2	1.4	1.6	—	—	—	
1000	L/min	140	95	57	26	—	—	
	kW	1.6	1.8	2.1	2.3	—	—	

Model 型式	min ⁻¹ 回転速度	Discharge amount 吐出量		Discharge pump head 吐出揚程 (m)				
		L/min	Required power 所要動力	5m	10m	15m	20m	25m
PH 50	600	L/min	110	40	—	—	—	—
		kW	0.9	1.4	—	—	—	—
	700	L/min	180	110	40	—	—	—
		kW	1.1	1.6	2.1	—	—	—
	800	L/min	260	180	120	80	30	—
		kW	1.2	1.7	2.2	2.7	3.2	—
900	L/min	315	240	180	135	90	—	
	kW	1.5	2.0	2.5	3.0	3.5	—	
1000	L/min	380	310	255	200	155	—	
	kW	1.7	2.2	2.7	3.2	3.7	—	

Model 型式	min ⁻¹ 回転速度	Discharge amount 吐出量		Discharge pump head 吐出揚程 (m)				
		L/min	Required power 所要動力	5m	10m	15m	20m	25m
PH 80	500	L/min	275	130	40	—	—	—
		kW	1.9	2.1	2.4	—	—	—
	600	L/min	380	275	180	100	30	—
		kW	2.3	2.8	3.2	3.7	4.1	—
	700	L/min	450	370	280	240	180	—
		kW	2.6	3.1	3.7	4.2	4.8	—
800	L/min	560	475	400	350	300	—	
	kW	2.9	3.6	4.7	5.5	6.4	—	

Model 型式	min ⁻¹ 回転速度	Discharge amount 吐出量		Discharge pump head 吐出揚程 (m)				
		L/min	Required power 所要動力	5m	10m	15m	20m	25m
PH100	500	L/min	425	290	200	100	40	—
		kW	2.7	3.1	3.5	3.9	4.3	—
	600	L/min	520	410	330	250	190	—
		kW	2.9	3.6	4.3	5.0	5.7	—
	700	L/min	630	500	430	360	290	—
		kW	3.2	4.1	5.0	5.8	6.7	—
800	L/min	800	670	590	500	—	—	
	kW	3.6	4.7	5.9	7.1	—	—	

Note 1: Performance represents the value under the condition that suction pump head is 1 m, temperature is ordinary, and water is fresh.

Note 2: Performance varies according to suction pump head and liquid quality.

Note 3: In the case of highly viscous or slime-like liquid, sludge, or the like, choose the low-speed rotation mode.

Note 4: Since this rotor is made of polyurethane rubber, its performance slightly deteriorates due to abrasion when it is operated continuously for a long period of time.

Note 5: If PH is 40-50 and suction pump head is over 3 m, set rotational speed at over 750 min⁻¹

(注1) 性能は吸込揚程1m、常温清水時の値です。

(注2) 吸込揚程、液質により性能は変化します。

(注3) 高粘度液・へどろ状液・汚泥等の場合には、低速回転にしてください。

(注4) ポリウレタンゴム製ロータのため、磨耗により長期連続運転後の性能は初期性能よりも若干低下します。

(注5) PH40・50で吸込揚程が3m以上の場合は、回転速度を750min⁻¹以上にしてください。

Performance Curve (fresh water) 性能曲線 (清水)

* Discharge amount varies by ±10%, because the product is made of rubber.

吐出量には±10%の差があります。(ゴム製のため)

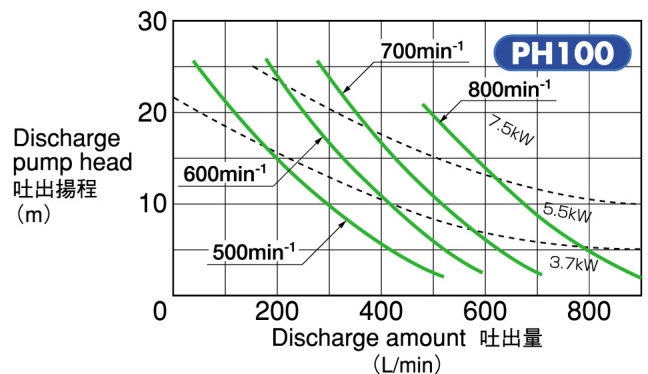
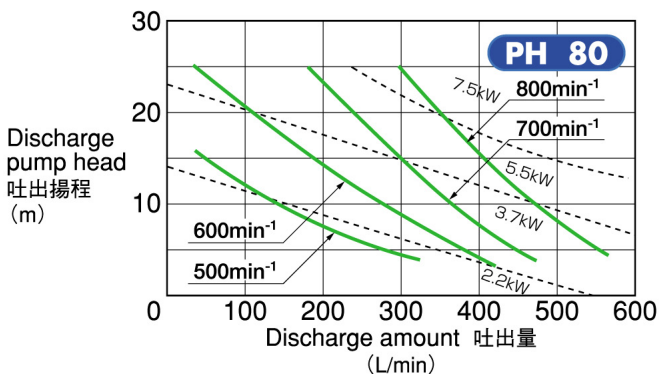
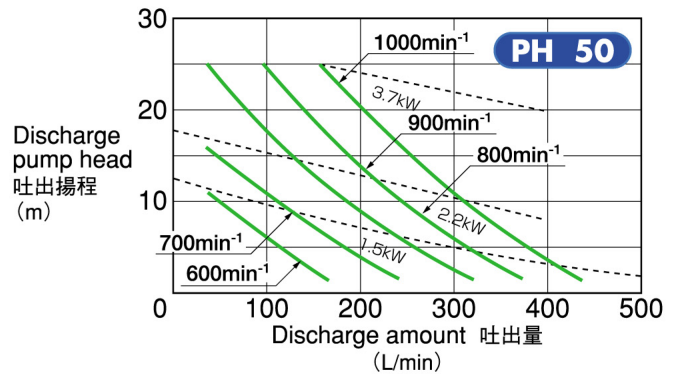
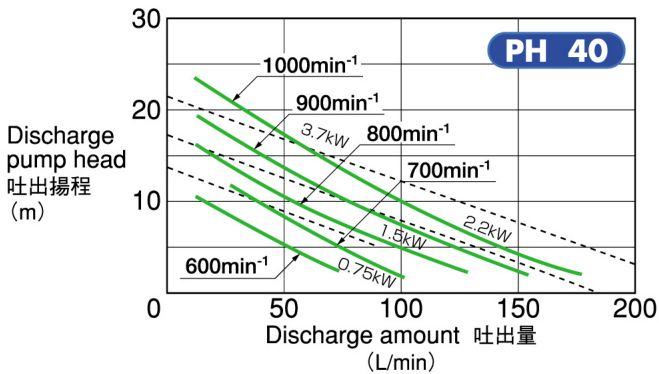

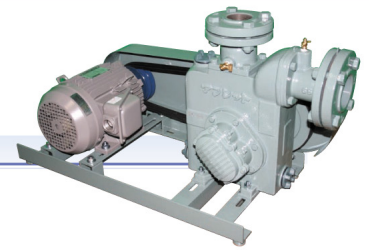

Outline Drawing 外形寸法図

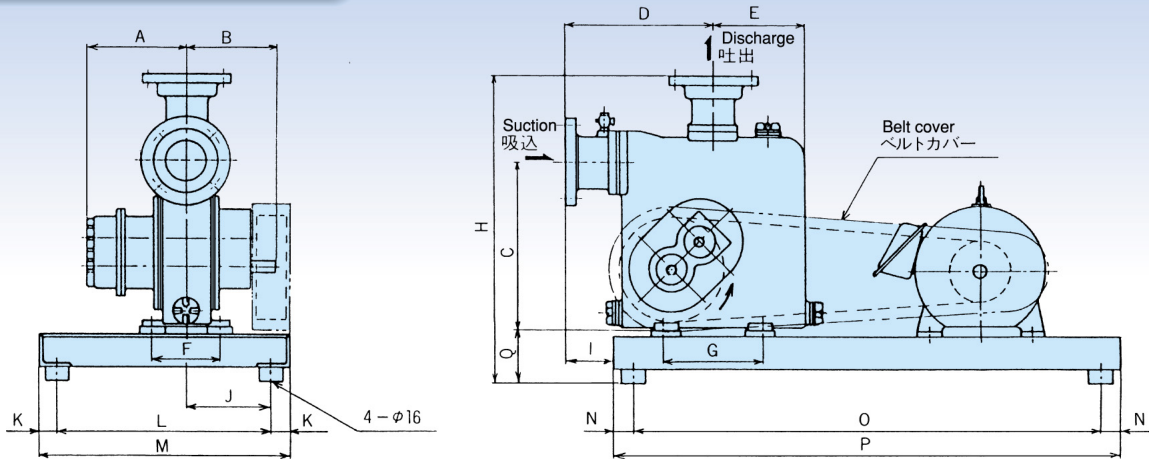

(JIS5K flange is a standard specification.)
(標準はJIS5Kフランジです。)

unit 単位 : mm

Model 型式	Bore 口径 Suction X Discharge 吸込 X 吐出	Phase flange 相フランジ	Pump ポンプ									Standard angle base 標準アングルベース							Weight (kg) 質量	
			A	B	C	D	E	F	G	H	I	J	K	L	M	N	O	P		Q
PH 40	50 ^A ×40 ^A	JIS 5 K	142	138	295	213	121	85	135	468	83	155	25	335	385	20	715	755	85	48
		JIS 10K	142	138	295	242	121	85	135	468	112	155	25	335	385	20	715	755	85	52
PH 50	65×50	JIS 5 K	167	163	290	230	131	130	135	465	112	175	25	335	385	20	715	755	85	60
		JIS 10K	167	163	290	236	131	130	135	475	118	175	25	335	385	20	715	755	85	64
PH 80	80×80	JIS 5 K	195	178	331	283	178	130	200	610	83	170	37.5	430	505	40	940	1020	110	100
		JIS 10K	195	178	331	303	178	130	200	620	103	170	37.5	430	505	40	940	1020	110	103
PH100	100×100	JIS 5 K	210	193	350	325	183	170	200	630	53	185	37.5	430	505	40	940	1020	110	118
		JIS 10K	210	193	350	325	183	170	200	630	53	185	37.5	430	505	40	940	1020	110	121

- Standard accessories: a base, a belt cover, a V pulley, a V belt, and a suction-discharge phase flange
- Mass represents the value that excludes the motor, but includes standard accessories
- According to motor capacity and rotational speed, suction port height (C size) and discharge port height (H size) may change.
- 標準付属品：ベース・ベルトカバー・Vプーリー・Vベルト・吸込吐出相フランジ
- 質量はモータを除いた標準付属品付の値です。
- モータ容量及び回転速度によっては、吸込口高さ(C寸法)ならびに吐出口高さ(H寸法)が変わることもあります。

Precautions 取扱上の注意事項

1. It is necessary to supply water once before the first operation. Detach the water-supply cap, to supply water. Also after water is removed from the pump, it is necessary to supply water.
2. It is normal to feel a little heavy when rotating the pulley by hand. The rotational direction is counterclockwise from the viewpoint of the pulley.
3. Set the pump near the suction part, at a low position. Minimize curved pumps, and thicken conduits.
4. Be sure to attach the strainer to the tip of the suction side.
5. If you use a suction hose at a civil engineering construction site or the like, be careful so that air will not enter from the joint part.
6. If suction pump head is high, the suction pipe is clogged, or viscosity is high, cavitation may occur, causing unpleasant noise. You can stop this noise by letting air in from the peacock at the suction side.
7. Replenish bearing grease once or twice per month, and side gear grease once or twice per year. For grease, use Albania No.2 (Showa Shell) or equivalents.
8. If boost pressure acts on the suction side, contact us.

1. 最初の運転前に1回だけ給水が必要です。給水キャップをはずして給水してください。また、ポンプ内の水を抜いた場合も同様です。
2. プーリーを手で回した時、少し重たく感じるのが正常です。回転方向はプーリー側から見て、反時計方向です。
3. ポンプの据付け位置は給水源に近く、かつ低くしてください。曲がり管は極力少なくし、また、管路は太くしてください。
4. 吸込側の先端にはストレーナを付けてください。
5. 土木現場等でサクシオンホースを使用する場合は、継手部から空気が混入しないようにしてください。
6. 高吸込揚程、吸込配管内の詰まりや高粘度の場合は、キャビテーションが発生し、不快な音が生じることがあります。吸込側のピーコックから空気を入れると不快な音はなくなります。
7. ベアリンググリスは1~2回/月補給してください。サイドギヤのグリスは1~2回/年補給してください。グリスはアルバニアNo.2(昭和シェル)または、同等品を使用してください。
8. 吸込側に押し込み圧力がかかる場合は、お問い合わせください。

SAVE THE EARTH

地球を守ろう



Note : Appearance and specifications are subject to change without notice.
※本カタログ記載内容については製品改良のため予告なく変更することがありますので、予めご了承下さい。

Made in JAPAN



ANLET CO., LTD.



URL : <http://www.anlet.co.jp>
E-mail : info@anlet.co.jp

Head Office : 25-1 Takara, Kanie-cho, Ama-gun,
Foreign division Aichi JAPAN 497-8531
TEL:+81-567-95-1211 FAX:+81-567-95-1220

Branches : Tokyo, Nagoya, Osaka, Sendai, Kitakanto,
Yokohama, Shizuoka, Hokuriku, Hiroshima,
Takamatsu, Fukuoka

本社・工場 〒497-8531 愛知県海部郡蟹江町宝1丁目25番地
海外事業部 TEL (0567) 95-1211 (代) FAX (0567) 95-1220

営業所 東京、名古屋、大阪、仙台、北関東、横浜、静岡、北陸、広島、高松、福岡

Agency
代理店